

A STUDY OF THEATRE FACILITIES IN USE
BY TEN CLASS AAA HIGH SCHOOLS IN KANSAS

A Thesis
Presented to
the Department of Speech
Kansas State Teachers College of Emporia

In Partial Fulfillment
of the Requirements for the Degree
Master of Science

by
Kevin L. Alexander
April 1971

David L. Matheny
Approved for the Major Department

James W. Boyle
Approved for the Graduate Council

ACKNOWLEDGMENTS

Sincere appreciation is expressed to my wife, Jolyne, who was understanding and thoughtful while this study was in progress.

Acknowledgment and appreciation are also extended to the administrators and speech faculty members of each of the ten high schools included within this study. The cooperation and assistance of each school district visited was essential to the completion of this study.

TABLE OF CONTENTS

| | PAGE |
|---|------|
| ACKNOWLEDGMENTS | i |
| LIST OF TABLES | vii |
| LIST OF FIGURES | viii |
| CHAPTER | |
| 1. THE PROBLEM | 1 |
| Importance, Justification, and Background of the Problem | 1 |
| Objectives of the Study | 5 |
| Statement of the Problem | 5 |
| Definition of Terms | 6 |
| Review of Literature | 6 |
| Procedure | 11 |
| Limitations of the Study | 13 |
| 2. ATCHISON | 14 |
| Auditorium House | 14 |
| Stage Area | 16 |
| Curtains and Scenery | 19 |
| Construction Area and Equipment | 19 |
| Storage Area | 20 |
| Dressing Rooms | 21 |
| Lighting | 21 |
| Sound | 22 |
| Communications | 23 |

CHAPTER

PAGE

| | | |
|----|---|----|
| 3. | BUHLER | 24 |
| | Auditorium House | 24 |
| | Stage Area | 25 |
| | Curtains and Scenery | 27 |
| | Construction Area and Equipment | 27 |
| | Storage Space | 28 |
| | Dressing Rooms | 29 |
| | Lighting | 29 |
| | Sound | 30 |
| | Communications | 30 |
| 4. | DECATUR COMMUNITY -- OBERLIN | 31 |
| | Auditorium House | 31 |
| | Stage Area | 33 |
| | Curtains and Scenery | 33 |
| | Construction Area and Equipment | 34 |
| | Storage Space | 34 |
| | Dressing Rooms | 35 |
| | Lighting | 35 |
| | Sound | 36 |
| | Communications | 36 |
| 5. | GARDNER | 37 |
| | Auditorium House | 37 |
| | Stage Area | 37 |
| | Curtains and Scenery | 39 |
| | Construction Area and Equipment | 39 |
| | Storage Area | 40 |

CHAPTER

PAGE

| | | |
|----|---|----|
| | Dressing Rooms | 40 |
| | Lighting | 41 |
| | Sound | 41 |
| | Communications | 42 |
| 6. | LYONS | 43 |
| | Auditorium House | 43 |
| | Stage Area | 45 |
| | Curtains and Scenery | 47 |
| | Construction Area and Equipment | 48 |
| | Storage Space | 50 |
| | Dressing Rooms | 50 |
| | Lighting | 50 |
| | Sound | 51 |
| | Communications | 52 |
| 7. | NEODESHA | 53 |
| | Auditorium House | 53 |
| | Stage Area | 53 |
| | Curtains and Scenery | 54 |
| | Construction Area and Equipment | 54 |
| | Storage Space | 56 |
| | Dressing Rooms | 56 |
| | Lighting | 57 |
| | Sound | 57 |
| | Communications | 58 |
| 8. | OTTAWA | 59 |
| | Auditorium House | 59 |

CHAPTER

PAGE

| | | |
|-----|---|----|
| | Stage Area | 61 |
| | Curtains and Scenery | 62 |
| | Construction Area and Equipment | 62 |
| | Storage Area | 63 |
| | Dressing Rooms | 63 |
| | Lighting | 65 |
| | Sound | 65 |
| | Communications | 65 |
| 9. | PARSONS | 67 |
| | Auditorium House | 67 |
| | Stage Area | 69 |
| | Curtains and Scenery | 69 |
| | Construction Area and Equipment | 70 |
| | Storage Space | 70 |
| | Dressing Rooms | 70 |
| | Lighting | 71 |
| | Sound | 72 |
| | Communications | 72 |
| 10. | ST. JOSEPH'S -- HAYS | 73 |
| | Auditorium House | 73 |
| | Stage Area | 74 |
| | Curtains and Scenery | 76 |
| | Construction Area and Equipment | 78 |
| | Storage Area | 78 |
| | Dressing Rooms | 79 |
| | Lighting | 79 |

| CHAPTER | PAGE |
|---|------|
| Sound | 80 |
| Communications | 81 |
| 11. TONGANOXIE | 82 |
| Auditorium House | 82 |
| Stage Area | 84 |
| Curtains and Scenery | 86 |
| Construction Area and Equipment | 86 |
| Storage Area | 87 |
| Dressing Rooms | 87 |
| Lighting | 88 |
| Sound | 89 |
| Communications | 89 |
| 12. SUMMARY AND CONCLUSIONS | 90 |
| Auditorium House | 90 |
| Stage Area | 90 |
| Curtains and Scenery | 94 |
| Construction Area and Equipment | 95 |
| Storage Area | 95 |
| Dressing Rooms | 96 |
| Lighting | 96 |
| Sound | 97 |
| Communications | 98 |
| Conclusions | 98 |
| BIBLIOGRAPHY | 100 |
| APPENDIX | 103 |

LIST OF TABLES

| TABLE | PAGE |
|--|------|
| 1. Table of Recommended Dimensions | 8 |
| 2. Space and Equipment Summary | 91 |

LIST OF FIGURES

| FIGURE | PAGE |
|--|------|
| 1. Auditorium, Atchison, Kansas | 15 |
| 2. Over-Stage Dressing Room, Atchison, Kansas | 17 |
| 3. Lobby, Atchison, Kansas | 17 |
| 4. Stage, Atchison, Kansas | 18 |
| 5. Basement Construction, Storage, Dressing, Atchison, Kansas | 18 |
| 6. Stage and Classroom, Buhler, Kansas | 26 |
| 7. Basement Storage and Green Room, Buhler, Kansas | 26 |
| 8. Stage, Auditorium and Lobby, Oberlin, Kansas | 32 |
| 9. Stage, Gardner, Kansas | 38 |
| 10. Storage Room, Gardner, Kansas | 38 |
| 11. Theatre Plant, Lyons, Kansas | 44 |
| 12. Stage, Lyons, Kansas | 46 |
| 13. Construction and Dressing Rooms, Lyons, Kansas | 49 |
| 14. Stage, Neodesha, Kansas | 55 |
| 15. Identical Storage Rooms, Neodesha, Kansas | 55 |
| 16. Auditorium House, Ottawa, Kansas | 60 |
| 17. Dressing Rooms Under-Stage, Ottawa, Kansas | 64 |
| 18. Auditorium House, Parsons, Kansas | 68 |
| 19. Auditorium, St. Joseph's, Hays, Kansas | 75 |
| 20. Stage, St. Joseph's, Hays, Kansas | 77 |
| 21. Storage, St. Joseph's, Hays, Kansas | 77 |
| 22. Auditorium House, Tonganoxie, Kansas | 83 |

FIGURE

PAGE

| | |
|---|----|
| 23. Storage, Tonganoxie, Kansas | 85 |
| 24. Lobby, Tonganoxie, Kansas | 85 |

Chapter 1

THE PROBLEM

IMPORTANCE, JUSTIFICATION, AND BACKGROUND OF THE PROBLEM

The secondary schools in Kansas have been producing plays for many years. Drama was not introduced as an academic discipline, but instead slipped into the school systems through the back door. Play production was introduced as a tool used by the schools to make money for a class, for the library, or for some other purpose.

Within the last twenty years theatre has made rapid advancement in the schools and has made great strides toward proving itself a useful discipline in the development of students physically, intellectually, and psychologically. The educational value of drama is being recognized, and with this recognition, the prestige of high school drama is improving. Many high school systems that considered drama to be a mere frill a few years ago are now contracting qualified drama instructors and are willing to support an educational theatre program. Even though high school drama has been produced under the most trying circumstances, writes Hedde, many modern high schools are constructing facilities that are excellent.¹

¹Wilhelmina G. Hedde, The New American Speech (New York: J. B. Lippincott Company, 1957), p. 424.

Never before has education in theatre been more important than it is today, because

we have become a nation of theatre-goers--even those who rarely see a professional play. The moving-picture, radio, and television, bring the theater to every town and into every home.²

A drama program of value can be expensive and often puts new demands on the already over-stretched school budget. The cost of equipment and the construction of costumes and scenery can become exorbitant. One may argue that drama can be produced anywhere and at any time, without the expense of costumes and other scenic effects. This argument is a good one, but it considers only the acting discipline as important. Indeed acting is an essential part of drama education, but in combination with acting, there is great value to be achieved in the study and creation of scenic effects in play production. Hibbs states that behind-the-scenes workers learn to "handle the many problems of business management as well as arranging make-up, properties, sound effects, lighting, costuming, and scenery."³

To produce a play, five elements are necessary. There must be a story presented by actors on a stage before an audience.⁴ By Smith's definition of play production, a

²Milton Smith, Play Production (New York: Appleton-Century-Crofts, Inc., 1948), p. 13.

³Paul Hibbs, Speech for Today (St. Louis: McGraw-Hill, 1965), p. 407.

⁴Smith, op. cit., 5.

play can be produced without the aid of scenic effects. These effects, or spectacle⁵ as they are referred to by Aristotle, are merely frills, and are not necessary to the successful production of most play scripts.⁶ The effects do, however, enhance the performance of a play by heightening the emotional impact of each scene. Scenic effect is capable of establishing the tone or mood of a play. The first contact that the audience has with a play is that of scenic effect. The pre-curtain music; the lighting in the auditorium; the effect achieved when the curtain first rises revealing the set; all of these serve to establish the tone or mood of the play before the action begins. In reference to Robert Edmond Jones, scenic effect in theatre is referred to as

a presence, a mood, a warm wind fanning the drama to flame. It echoes, it enhances, it animates. It is an expectancy, a foreboding, a tension. It says nothing, but gives everything.⁷

A dramatic production should be worthy of all that the theatre represents--and scenic effect is definitely an important element of a theatrical production.

The necessity for adequate stage facilities for secondary school theatres was supported by Ogilvie when he wrote,

⁵Aristotle, Poetics, 1450 b 17.

⁶Aristotle, Poetics, 1450 b 19.

⁷Robert Edmond Jones, The Dramatic Imagination (New York: Theatre Arts Books, 1941), p. 24.

It (high school drama) should give its members a chance to participate in all phases of theatre; acting, designing and constructing scenery and costumes, working out lighting effects, making up characters, and developing business acumen in theater management.⁸

The same position was supported by Braden when he wrote as one of the objectives of high school theatre, "To gain understanding and control over expressive mechanisms."⁹ In his objectives for high school theatre, Wright echoed, "Our high school theatres should always endeavor to encourage creative work in every phase of the dramatic art."¹⁰

If plays are to be produced, an adequate auditorium, stage, and equipment are essential. Plays produced in a poorly planned and equipped theatre prove costly to the school's drama program. Burriss wrote that "the educational program is vitiated"¹¹ in a poorly planned auditorium. He goes on to write that:

half a theatre is as bad pedagogically as half a play. Plays produced under limitations are shabby, and invite a patronizing attitude on the part of the audience.¹²

⁸Mardel Ogilvie, Teaching Speech in the High School (New York: Appleton-Century--Crafts, Inc., 1961) p. 307.

⁹Waldo W. Braden, Speech Methods and Resources (New York: Harper-Row, 1961) p. 348.

¹⁰Edward A. Wright, Understanding Today's Theater (New Jersey: Prentice-Hall, Inc., 1962) p. 134.

¹¹Harold Burriss, Theatres and Auditoriums (New York: Reinhold, 1949) p. 9.

¹²Ibid.

The scenic aspects of theatre are important to the total effect achieved by a dramatic production, and consequently deserves serious consideration and study. Therefore the problem investigated in this study comes to light.

OBJECTIVES OF THE STUDY

This study is set forth to accomplish the following objectives:

1. Compile an authoritative list of recommended theatre dimensions and arrangements useful to enable the best quality of play production.
2. Study and illustrate theatre facilities under construction or in use by ten Class AAA High Schools in the state of Kansas.
3. Point out the strengths and weaknesses in the theatre facilities of the ten Class AAA High Schools studied.

STATEMENT OF THE PROBLEM

The purpose of this study was twofold: First to investigate the kind and quality of theatre facilities being constructed or in use by ten Class AAA High Schools in the state of Kansas, and second, to establish the adequacy or inadequacy of these theatre facilities to enable the best quality of production. The problem is thus stated: Do the theatre facilities being constructed or in use by ten

Class AAA High Schools in Kansas possess the necessary space, arrangement, and equipment to enable the best quality of play production?

DEFINITION OF TERMS

Theatre Facilities. The term theatre facilities refers to all of the areas in which work takes place during the production and performance of a play.

Class AAA High Schools. Class AAA High Schools refers to those high schools that are classified AAA by the Kansas High School Activities Association. AAA classification is based on an enrollment of not less than 223 students, and not more than 630 students in the combined tenth, eleventh, and twelfth grades.

REVIEW OF LITERATURE

Before the objectives of this study could be achieved, the purpose of drama in high school education had to be explored and defined, and some agreement reached concerning the theatre facilities necessary to achieve that purpose. Most authorities that write concerning the purpose of drama, emphasize the development of students vocally, physically, emotionally, and culturally. Through their discussion of how the purpose of drama can be achieved, some mention the importance of values gained through technical experience, but few emphasize the importance of scenic effect enough to discuss the facilities necessary to

properly fulfill that purpose in drama. Upon reviewing the recommendations made by authorities, one finds disagreement among them concerning theatre facility requirements. Following is a table of recommended theatre dimensions as established by the listed authorities.

TABLE OF RECOMMENDED DIMENSIONS¹³

| [Source] By | Seats | [Proscenium] Pro Height | [Proscenium] Pro Width | Stage Floor Height |
|------------------|----------|-------------------------------|------------------------------|--------------------------|
| Evenden, etc. | 250+ | | | 3½'-4' |
| Bel Geddes | | | | |
| Granville-Barker | | | 30' or 25'-40' | |
| Hume & Foster | | 12' | 24' | 3'9" or 3'6"-4' |
| Keisler | | 10'-20' | 20'-35' | |
| Klauder & Wise | 500 | | 25'+ | |
| Linnell | | 25' | 30' | |
| Lyndon | | | | |
| McCandless | 500-700 | | | 2'6"-3' |
| Lee Mitchell | 750 | 18' | 30' | 3'9" |
| Neutra, etc. | 300-1000 | | 25'+ | 30"-36" |
| Pechel | | 12'+ | 24'+ | 3'9" |
| Simonson | 500-750 | 15'-20' | 30' or 24'-32' | 2'8" or 2'-3' |
| Smith | | 15' or 10'-15' | 30' or 20'-40' | |
| Stratton | 730-990 | | 35'-40' | |

¹³Marion W. Robinson, College Theatres of Tomorrow,
(Doctoral Dissertation, University of Wisconsin, 1945),
p. 134.

TABLE OF RECOMMENDED DIMENSIONS¹⁴

| [Source] By | Stage Height [Loft] | Stage Depth | Stage Width | Stage Area |
|------------------|--------------------------------|---------------------------|---------------------------|------------------|
| Evenden | 2½ x Pro. | | 2 x Pro.+ | |
| Bel Geddes | 4 x Max. Scene | | | 3 x act. area |
| Granville-Barker | | 60' | 100' | |
| Hume & Foster | Pro. x 2+5 | 25'+ | 2 x Pro. | |
| Kiesler | 60' | 16'-30' | 30'-55' | |
| Klauder & Wise | 60'+ | 30' | | |
| Linnell | 50' | 20'-30' | | |
| Lyndon | 2 1/3 x Pro. | 35'-50' | 2 x Pro. | 3 x act. area |
| Lee Mitchell | 75' | 30' | 60' | |
| Neutra, etc. | 2-3 x Pro.+8 | 25'+ | 50'+ | |
| Pichel | 36'+ | 24'+ | 2 x Pro. | 3 x act. area |
| Simonson | 55'-90' 2 1/3- 2½ x Pro. | 25'-60' 1½-2 x Pro. | 60'-100' 2-3 x Pro. | 3 x act. area |
| Smith | Pro.+6- Pro.x3 | 2/3 Pro.+ | Pro.+ 12-18 | |

¹⁴Ibid., p. 135.

ADDITIONAL DIMENSIONS¹⁵

| [Source] By | [Proscenium] Pro. Seats | Pro. Height | Pro. Width | Stage Height [Loft] | Stage Depth | Stage Width |
|--|-------------------------------|----------------|---------------|---------------------------|----------------|----------------|
| Clapp & Shaw | | | 30' | Pro.+4' | 30' | |
| Ebey | | 20' | 30' | 56' | 25' | 50' |
| Engelhardt | 800 | 12'- 20' | 24'- 35' | 2½ x Pro. | 25'+ | 60' |
| Fuchs | 750- 1000 | | 30'- 35' | 3 x Pro. | Pro. Width | 2 x Pro. |
| Gillette | | 14'+ | 30' 32' | 2½ x Pro. | 1½ x Pro. | 3 x Pro. |
| Harmon | | 20'- 40' | 30'- 60' | | 30'+ | 3 x Pro. |
| National Council on School Construction | 400- 600 | | 24' 30' | | 25' | |
| Manual for Architects | | | 30'- 40' | 2½ x Pro. | 30'+ 35' | 2 x Pro. |
| School of Ed. U. of Wis. | | 14'+ | 26'- 32' | | 25' | 2 x Pro. |

¹⁵Ibid., p. 136.

PROCEDURE

The Kansas State High School Activities Association has divided the high schools in the state of Kansas into five categories on the basis of total enrollment in grades 10, 11, and 12. The classifications are Class A, Class AA, Class AAA, Class AAAA, and Class AAAAA. The Class A and Class AA schools have relatively small enrollments, and only a small number of them have qualified drama instructors. The Class AAAA and Class AAAAA schools have large enrollments, and all have qualified drama instructors, but they are concentrated to a great degree in the eastern and central portions of Kansas.

This study is concerned with the Class AAA schools because the majority of Class AAA Schools (all except six of the 64 schools) have qualified drama instructors, and the schools represent every area in the state of Kansas.

To avoid error in the conclusions drawn by this study, all of the 64 centers should have been studied and described. The time and expense involved in such a project would be exorbitant. Therefore a sampling of ten of the 64 Class AAA High Schools was studied, and recommendations made are based on that sampling.

With such a small sample, one must be aware of the great margin of error that might exist under random sampling selection. This study should include all areas within the state of Kansas, and it should represent both the large and

the small Class AAA school. Random sampling could fail on both counts, therefore random sampling was not used.

In order to assure that every part of the state be included in the study, two schools were chosen from each of the five congressional districts in the state. The congressional districts are established on the basis of population, so a legitimate cross section sampling of the state of Kansas should be achieved. The two schools selected from each congressional district were based on their 1968-69 school year enrollment, and from each district was chosen the AAA schools with the largest and the smallest enrollments. Selection through this system should insure a fair and accurate account of the kind and quality of theatre facilities in use in the Class AAA schools in the state of Kansas.

Each school selected for the study was visited by the researcher. A prepared information questionnaire was filled out during the researcher's visit. The theatre facilities questionnaire may be seen in the appendix, page 104 of this study. A complete, to scale, drawing was made of the auditorium, stage house, dressing rooms, construction area, etc. The information gathered from the ten selected schools was compiled and a discussion of the strengths and weaknesses of the theatre facilities in Class AAA High Schools in the state of Kansas was then made.

LIMITATIONS OF THE STUDY

This study was limited by one important factor. Since it was not possible to include all of the Class AAA High Schools in the state of Kansas within this study, the strengths and weaknesses of the theatre facilities found in the sample might not be indicative of the majority of cases in the state. Therefore the researcher's evaluation of the technical theatre facilities in Class AAA High Schools in the state of Kansas must not be construed to be indicative of every facility in the state.

Chapter 2

ATCHISON

Atchison High School is the largest Class AAA high school in the Second Congressional District. The present enrollment in grades 10, 11, and 12 total 534 students.

AUDITORIUM HOUSE

Atchison's high school facility was expanded as the enrollment increased with portions of the building being constructed in different years. The portion of the structure housing the auditorium was constructed in 1953. A floorplan of the auditorium may be seen in Figure 1 on page 15.

The seating capacity of the auditorium is 1,200 in traditional type seating with a center and two side aisles. The auditorium is designed with a balcony which accommodates approximately one third of the total seating. The floor is concrete with carpeted aisles. The length of the auditorium from the proscenium line to the back wall is 104 feet, 6 inches. The width at the rear is 68 feet and curves gently to a 36 foot proscenium opening. The curved lines of the walls and the ornately cut decorative trim create a fine atmosphere for theatre production.

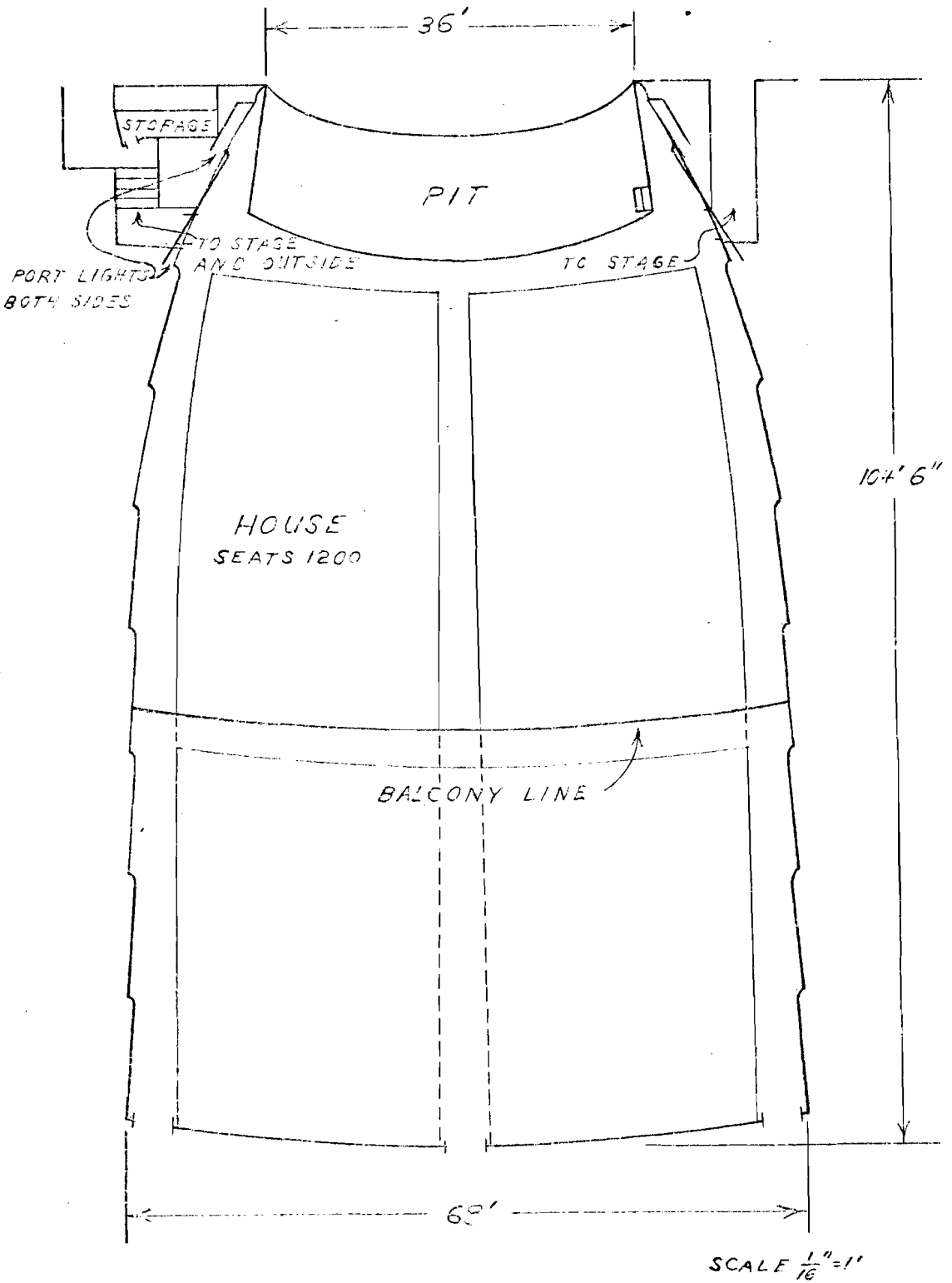

FIGURE 1
AUDITORIUM, ATCHISON, KANSAS

Passage from the auditorium to the back stage area is possible from both the left and right auditorium floor. Below the curve of the stage apron, a full orchestra pit is provided.

The lobby dimensions are 68 feet long and 29 feet deep, providing 1,972 square feet of lobby space. Two sets of stairs lead from the lobby to the balcony entrances. At one end of the lobby, large double doors lead to the outside. At the other end the lobby adjoins a hallway leading to other parts of the school building. A floor plan of the lobby may be seen in Figure 3, page 17.

STAGE AREA

The stage at Atchison High School is a proscenium stage. A detailed drawing of the stage may be seen in Figure 4, page 18. The proscenium opening is 36 feet wide and 16 feet high. There is a full loft of 40 feet. The stage left wing space is 17 feet by 27 feet, and the stage right wing space is a slightly smaller 15 feet by 27 feet. The total wing space equals 864 square feet. The stage depth from the proscenium line to the back wall is 27 feet. The stage apron curves an extension of 5 feet beyond the proscenium line. The floor covering is of non-polished hardwood. A trap measuring 8 feet by 8 feet is located in the stage right rear portion of the acting area. The trap was provided to allow the movement of scenery from the basement construction and storage area to the stage level. A 6 foot

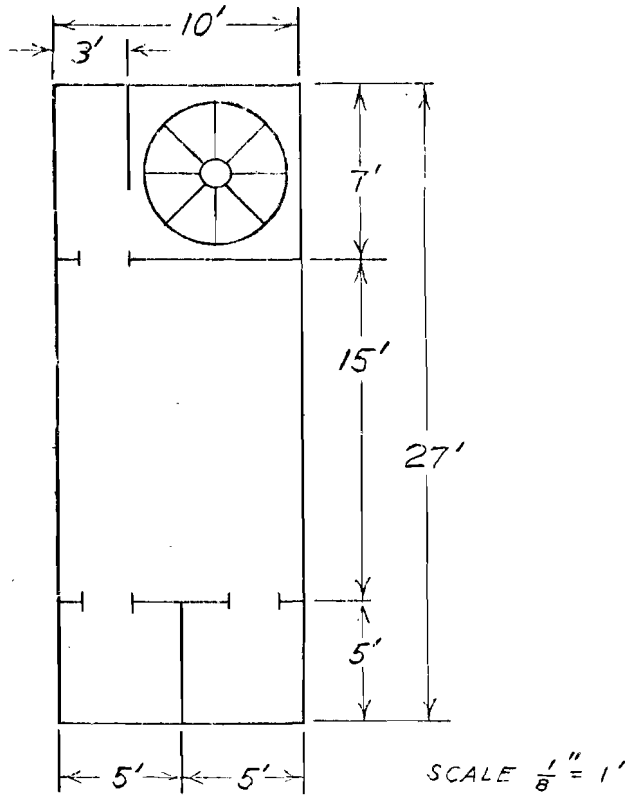

FIGURE 2
OVER-STAGE DRESSING ROOM
ATCHISON, KANSAS

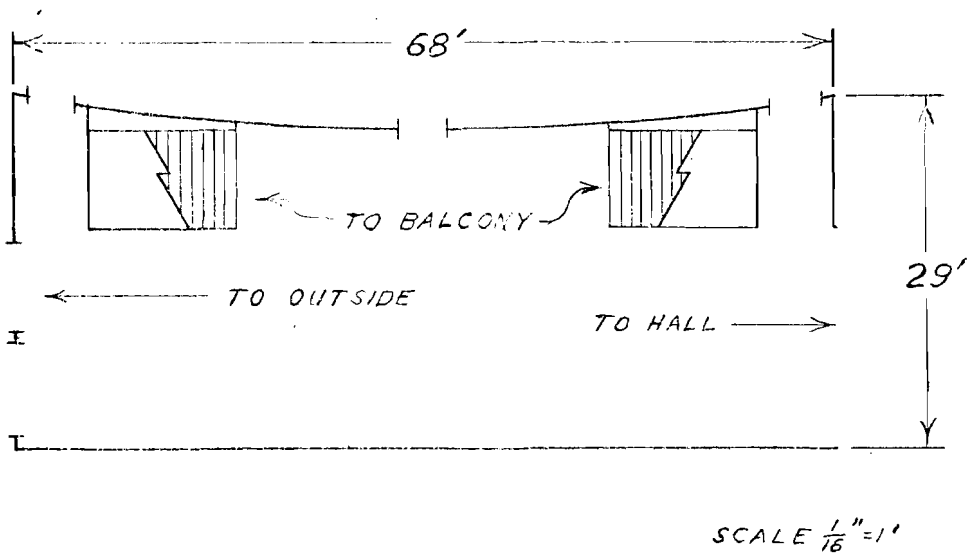

FIGURE 3
LOBBY, ATCHISON, KANSAS

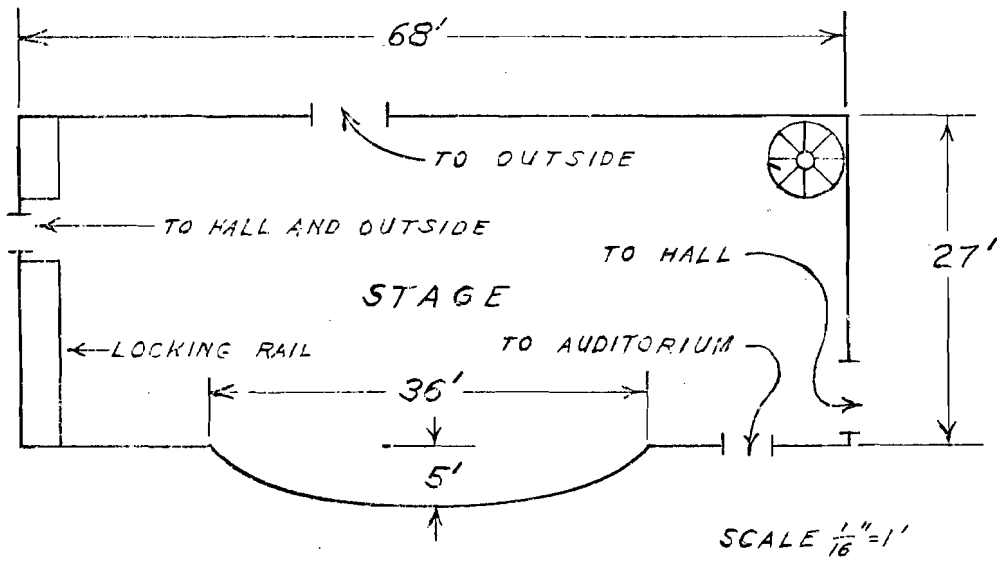

FIGURE 4
STAGE, ATCHISON, KANSAS

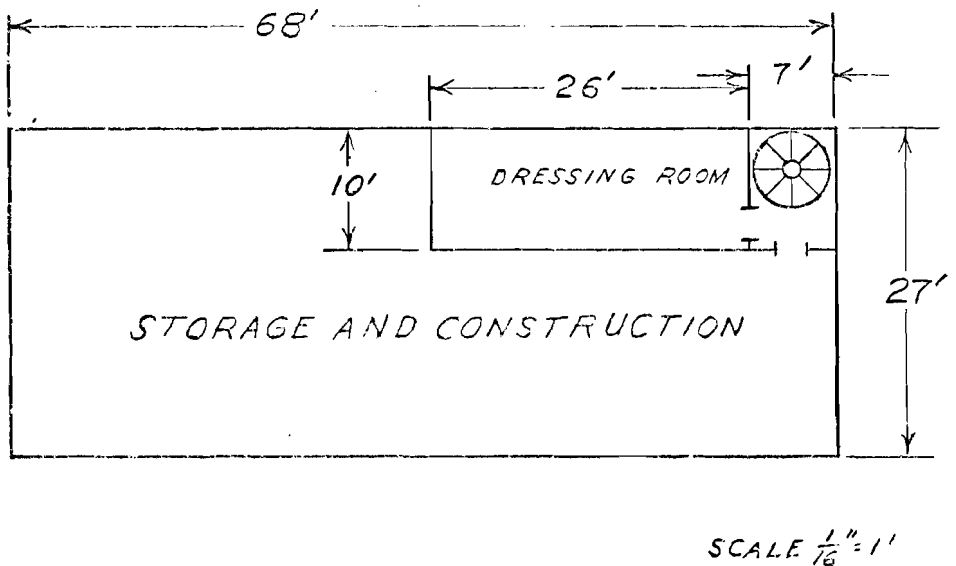

FIGURE 5
BASEMENT CONSTRUCTION, STORAGE, DRESSING,
ATCHISON, KANSAS

wide loading door to outside is located in the rear stage wall. The stage rigging is a counterweighted system consisting of 17 counterweighted lines. An open ladder from the stage floor to the grid is located on the rear wall.

CURTAINS AND SCENERY

The auditorium at Atchison High School is equipped with an act curtain and matching teaser of gold cotton material with small orange, green, and black figures. In addition to the act curtain there is a loose hanging tan colored cyclorama to enclose the acting area. There are four pairs of legs with teasers to match the pleated cyclorama. All curtains are lined. There is also a light blue streaked sky cyclorama measuring 42 feet by 16 feet. There are no painted backdrops and there is no scrim.

CONSTRUCTION AREA AND EQUIPMENT

Atchison High School auditorium is constructed with a basement workshop and storage area. The entire area under the stage is for construction and storage with the exception of one corner which serves as a dressing room. A scaled drawing of the storage and construction area may be seen in Figure 5, page 18. The only access to the construction-storage area is a spiral stairs which necessitates the use of the trapped stage floor to move scenery pieces from one level to the other. The ceiling

height in the basement area is only 9 feet, limiting to a great extent the value of the area for construction. Because of the ceiling height limitation, much of the construction is done on stage.

An ample supply of hand tools are available for construction, but there is a shortage of power tools. The only power tool found in the scene shop is a three-eighths inch electric drill. All other power tools are borrowed from the school woodshop as they are needed.

The work area is well arranged and well lighted. A large slop sink is located near the paint area, and ample floor space is available for construction projects.

STORAGE AREA

The major storage of drama supplies is in the construction area under the stage. A cabinet for paint storage is located along one wall. The capacity of the paint cabinet approximates 112 cubic feet. Another cabinet with an approximate capacity of 48 feet is provided for storage of hardware. A flat rack fills one corner of the basement room. Because of the low ceiling, flats are stored in the rack on edge.

Another small room is available for storage near the stage. It is located on the stage right side and may be seen in Figure 1, the auditorium floor plan, page 15. The room has an approximate capacity of 320 cubic feet, and is used primarily for the storage of lighting equipment.

DRESSING ROOMS

Atchison High School stage is designed with two dressing rooms. One is located in the basement area under the stage; the other is located on a mezzanine area above the stage floor. Both dressing rooms are reached via the spiral stairs, locating them an equal distance from the stage. The basement dressing room may be seen in Figure 5, page 18. The over-stage dressing room is scaled in Figure 2, page 17. Both dressing rooms have hot and cold running water and toilet facilities. The make-up lighting is overhead incandescent. Narrow make-up shelves are mounted on the dressing room walls with mirrors above. The dressing rooms are adequate, but they are neither convenient nor pleasant.

LIGHTING

Atchison High School stage is equipped with a Metropolitan Lumi-Tron rheostat dimmer board. The board is located on the stage right proscenium wall. The total capacity of the light board is 30,000 watts divided among 22 dimmer controls. The board is equipped with two group masters and one house master. Space is provided on the board for more dimmer controls to be added when desired.

The first light pipe is lined with fourteen 6 inch fresnels which are wired direct and cannot be removed from the pipe. Lighting instruments at Atchison High School

include sixteen 6 inch fresnels, supplied by Kliegl Brothers. There are six 8 inch ellipsoidal reflector spotlights, all located in the beam position. They are also supplied by Kliegl Brothers. There are nine 10 foot sections of three circuit striplight units, hung in three 30 foot banks. All are equipped with color glass rondels in red, white, and blue. All are wired directly to the light board for dimming. There are no floodlights. Two Trouperette followspots are among the inventory of lighting equipment. There are also two 1,000 watt incandescent followspots. There is no spare electrical cable with the exception of a few short dropcords. Seven floor pockets are provided in the stage floor. There are three floor pockets in the stage right area, and three in the stage left area. The seventh electrical pocket is located center stage near the rear of the acting area. Each floor pocket contains two electrical receptacles. In addition to the floor pockets there are two other outlets on stage. One is located on the rear wall, the other is on the stage left proscenium wall. Each is equipped with three, two-prong household outlets. There are 12 three-outlet household type plugs located in the orchestra pit.

SOUND

The sound equipment is located in a room across the hall and in an area separate from the stage. The position is such that visual contact with the stage is impossible.

The only contact the sound operator has with the production is that of audio communication with the stage manager, or if desired, a pick-up mike may be located on stage from which the sound operator may monitor the production. The equipment in the sound room includes a console housing a 180 watt amplifier, one four-speed turntable, and one three-speed, two track tape deck. Two house speakers are mounted on the auditorium walls, and five microphone pick-ups are located on stage. One pick-up is located in the center down stage floor, one on the stage left proscenium wall, and three on the stage right proscenium wall.

COMMUNICATIONS

A communication system is provided which permits communication between the following auditorium areas: Light board, sound room, stage manager position, stage right, stage left, and orchestra pit.

Chapter 3

BUHLER

Buhler High School represents the largest Class AAA high school in the Fourth Congressional District. The original structure was completed in 1933, and since that time two additions have been added. One addition was completed in 1953, and the other in 1959. The portion of the structure housing the auditorium was constructed in 1933. In the year 1970, Buhler High School underwent an evaluation by the North Central Accrediting Association, and the following quotation is their recommendation.

The auditorium appears obsolete and unsatisfactory in its present condition. The people in the district should consider providing a new auditorium to seat at least 750 people. Preferably, during the construction of the auditorium, other related auxiliary facilities should be provided, such as stage, dressing rooms, lobby, corridor space, and toilet facilities.¹⁶

A new auditorium is at this time under consideration by the school district.

AUDITORIUM HOUSE

Buhler High School has never had an auditorium. In the original 1933 structure, a gymnasium was constructed with a stage at one end creating a gymnasium-auditorium

¹⁶North Central Association Evaluation Report, Buhler High School, Feb. 25, 26, 27, 1970.

combination. In the 1959 addition to the school building a new gymnasium was included. The 1933 construction was then abandoned by the athletic and physical education department, leaving the old gymnasium for full time use as an auditorium and/or classroom. Since that time no improvements have been made in the structure, so that at this time it may still be best described as a gymnasium. The floor is flat, there is no fixed seating, and windows line one wall of the structure. The building is in need of repair and decoration. The area is used daily by the high school band.

There is no lobby adjoining the auditorium. The only space that could be called lobby is a hallway measuring 8 feet by 16 feet. There is a small ticket booth jammed in one corner. There is no coat check.

STAGE AREA

The stage is of the proscenium type. The proscenium opening is 28 feet and the height measures 13 feet. There is no loft above the stage area. The wing space stage left and stage right are identical, each measuring 16 feet by 15 feet 4 inches. The total wing area is 490.67 square feet. Stage depth from the proscenium line to the back wall is 15 feet 4 inches. A loading door to the outside is located in the stage right wall. A floor plan of the stage may be seen in Figure 6, page 26. There is no orchestra pit. The apron extends three feet beyond the proscenium line, and

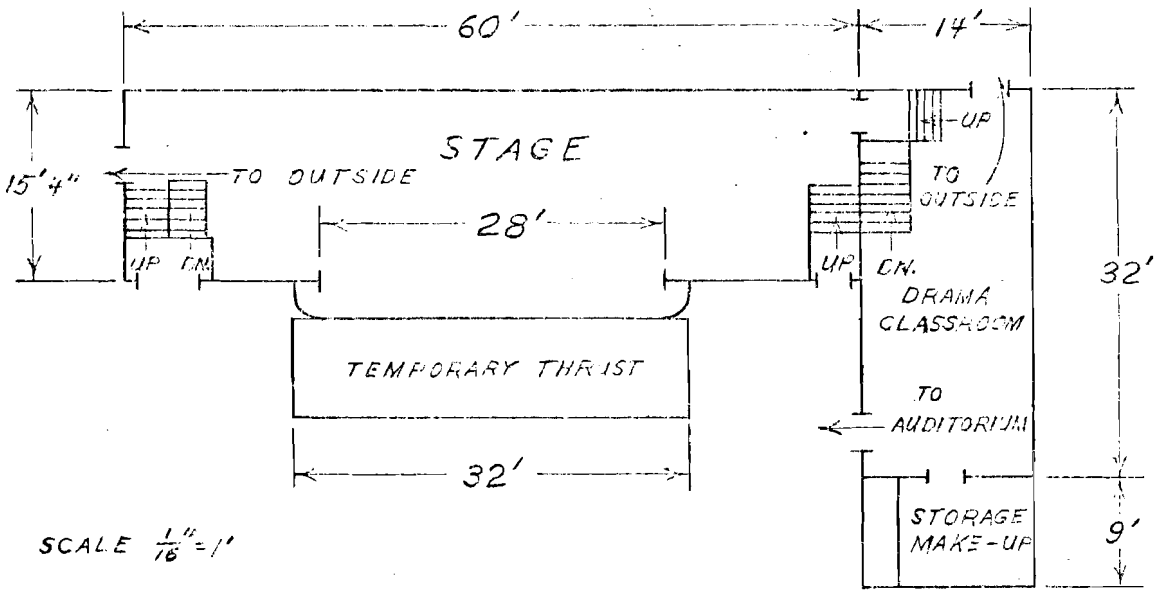
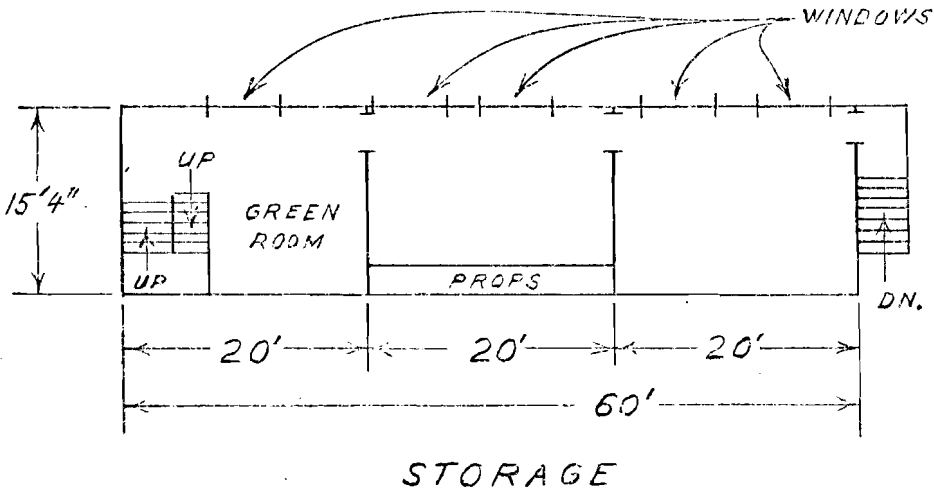

FIGURE 6

STAGE AND CLASSROOM, BUHLER, KANSAS



SCALE $\frac{1}{16}'' = 1'$

FIGURE 7

BASEMENT STORAGE AND GREEN ROOM
BUHLER, KANSAS

an 8 foot temporary thrust has been added for use by the high school band. The stage floor is of hard oak with a varnished finish. The floor is not trapped. Two weighted lines serve to handle two banks of border lights. There are no other lines for handling lights or scenery.

CURTAINS AND SCENERY

The curtains for use on the Buhler High School stage are new. They were purchased only one year prior to the date of this study. The school district chose to purchase only the most inexpensive of curtain material since the plan is to replace the auditorium and stage in the near future. The act curtain is of a very light weight, turquoise colored, cotton material. It is lined. A loose hanging pleated cotton cyclorama is tracked to enclose the back and sides of the acting area. It is a silver color and was supplied with two matching teasers. There are two professionally painted back drops to be used as scenery. Both are painted foliage and are on roller battens for storage. There is no scrim or other scenery pieces.

CONSTRUCTION AREA AND EQUIPMENT

There was no construction area provided in the theatre design. All construction is accomplished on the stage floor or in the high school woodshop. The location of the stage loading door to the high school woodshop is not convenient.

An assorted few hand tools are the property of the theatre department, but there are not nearly enough to properly complete the construction of a play set. To accomplish set construction, hand and power tools must be borrowed from the woodshop.

STORAGE SPACE

Storage is provided in three areas. The largest storage area is the basement below the stage. The basement area may be seen in Figure 7, page 26. It consists of three rooms that were designed to be used as locker and shower rooms for athletic or physical education purposes. Since the construction of the new gymnasium, the lockers and showers have been removed and the theatre department now occupies the area. One of the rooms has been converted into a sort of semi-green room storage area. Another of the rooms has a series of shelves along one wall for the storage of props and stage hardware. The third room is open storage. Another area in which storage is possible is a 64 square foot platform which exists on stage above the stage left stairway to the auditorium. The platform is 7 feet 3 inches above the stage floor. Storage is also possible in the drama classroom and in an adjoining room to the classroom. A scaled drawing of the classroom and adjoining storage area may be seen in Figure 6, page 26. Stairways lead from the drama classroom to both the basement storage area and to the stage. The room adjoining the

classroom is used primarily for the storage of make-up, a few costumes, and is used as a dressing room and make-up room for play production. The classroom is equipped with one lavatory with running water and a drain.

DRESSING ROOMS

No dressing rooms were provided in the theatre design. The drama classroom and the adjoining room are used for dressing and make-up. The single lavatory in the drama classroom makes running water available. A floor plan of the area may be seen in Figure 6, page 26.

LIGHTING

Buhler High School stage is equipped with a three unit rheostat dimmer, wired direct, to control two banks of border lights. The capacity of each dimmer is 4,000 watts, totaling a capacity of 12,000 watts for the three dimmers. The dimmer control is located on the stage right proscenium wall. The two units of borderlights are each 18 feet long and are divided into three circuits. They are trough type units designed to receive standard medium base type "A" incandescent lamps. A three circuit row of footlights is also provided. Other lighting equipment includes five 6 inch fresnels, two 6 inch and two 4 inch ellipsoidal reflector spotlights, one 10 inch floodlight, and one 1,000 watt followspot, all supplied by Capitol Lighting. A small amount of lighting equipment has been constructed by the

theatre department. It includes three 600 watt household incandescent dimmers, and six R-40 lamps with bases. There is about 200 feet of dropcord in assorted lengths to make short cable runs. There are two electrical outlets in the stage floor and no others in the stage area. There are none in the apron area of the stage.

SOUND

A sound system was not provided for use on the stage. A portable public address unit is brought in for such events as school assemblies and commencement. There are no provisions made for electric sound effects at play productions.

COMMUNICATIONS

There is no communication system provided.

Chapter 4

DECATUR COMMUNITY -- OBERLIN

Decatur Community High School is the smallest Class AAA high school in the First Congressional District. The original building was constructed in 1938 and one addition has been made to the building since that time. The total enrollment in grades 10, 11, and 12 is 225 students.

AUDITORIUM HOUSE

The Decatur Community High School auditorium is located in the original structure completed in 1938. The auditorium is designed to seat 701 people in traditional seating style. There is no balcony. The architectural design is pleasing and the auditorium is in good repair. A floor plan of the auditorium may be seen in Figure 8, page 32.

The auditorium measures 74 feet 6 inches from the proscenium line to the back wall. Its width is 52 feet. Two aisles divide the seating into three blocks. A doorway on either side of the proscenium opening leads to the back stage area. A series of tall, narrow windows line the outside wall of the auditorium.

The lobby is small, measuring only 42 feet by 12 feet 8 inches. A small ticket booth is squeezed into one

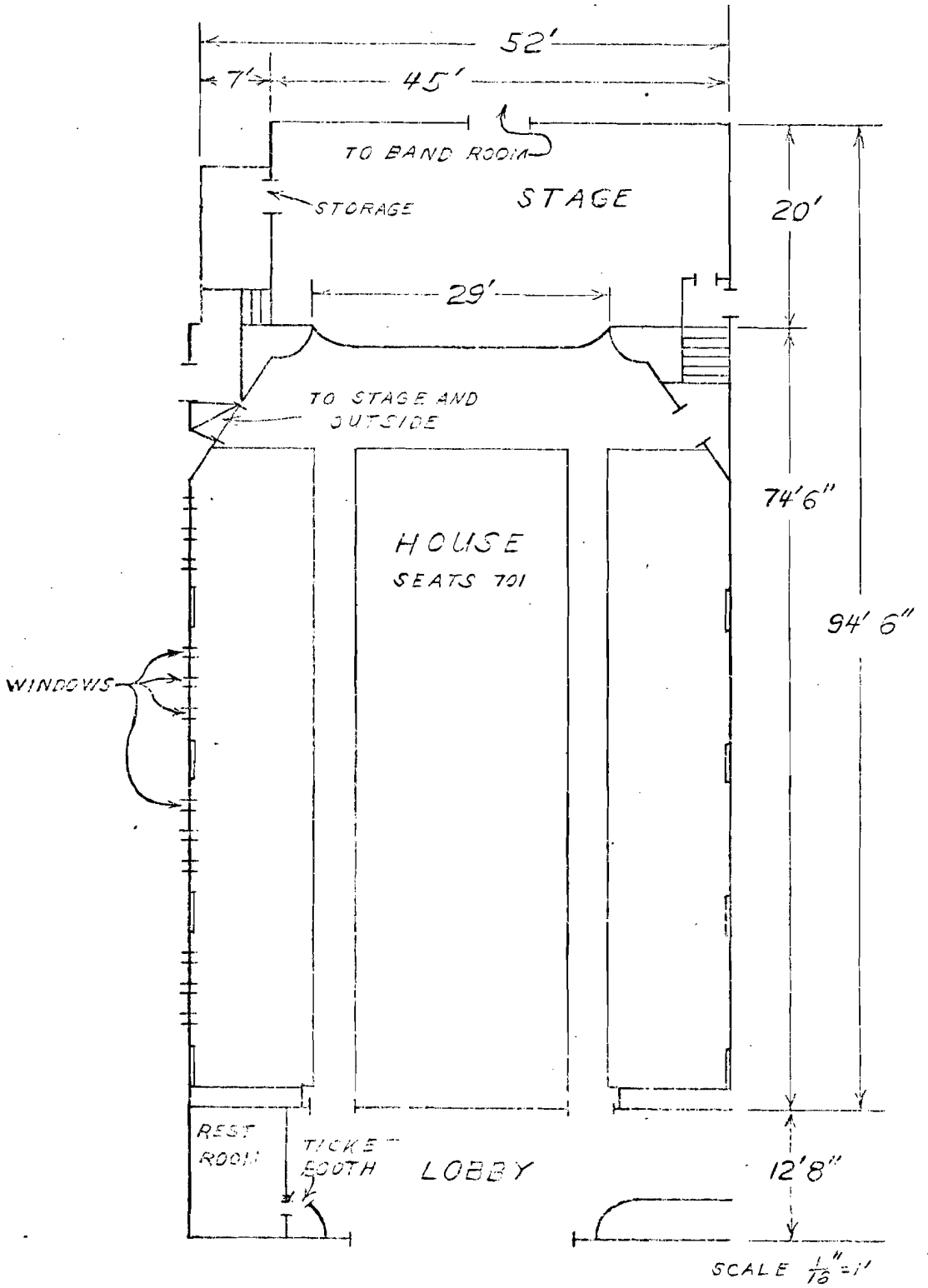

FIGURE 8
 STAGE, AUDITORIUM, AND LOBBY
 OBERLIN, KANSAS

corner with a restroom behind it. Another restroom is located in a nearby hallway. There is no coat check.

STAGE AREA

A scaled drawing of the stage area may be seen in Figure 8, page 32. The stage is of the proscenium type with the proscenium opening measuring 29 feet. The height of the proscenium opening is 14 feet. The stage depth is 20 feet from the proscenium line to the back wall and the full stage width is 45 feet. The stage apron extends two feet beyond the proscenium line. There is no orchestra pit. The distance from the apron to the first row of seats is ten feet. The stage wing area is small, measuring 200 square feet on the stage left side and only 80 square feet on the stage right side. There is no loft. All scenery and light battens are permanently hung. The stage floor is of soft wood. The floor is not trapped. A 6 foot wide loading door was provided in the original structure, but the new addition was designed with the music department attached to the rear wall of the stage. The original loading door now leads into the band room.

CURTAINS AND SCENERY

Decatur Community High School stage is equipped with a green velour act curtain. The curtain has matching returns and two matching teasers. All are lined with green cotton. There is a concert curtain, also of velour, in a tan color

with a black cotton lining. The side and rear masking is achieved by three pleated cyclorama curtains, all tracked to travel open and closed. The cyclorama pieces are of a cotton material in a burlap weave and in burlap color. There are two matching teasers. None of the cyclorama material is lined. There are no painted backdrops and there is no scrim.

CONSTRUCTION AREA AND EQUIPMENT

No provisions were made for the construction of scenery. There is no scene shop of any kind provided. All construction is done on the stage floor or in the high school woodshop. The high school woodshop is not conveniently located for stage construction or for moving scenery pieces in or out. The theatre department does not own any tools, hand or power. All tools necessary for construction are borrowed from the school woodshop.

STORAGE SPACE

The only room provided for storage is a small room measuring 7 feet by 11 feet 6 inches. In this room all Decatur High School theatre materials are stored. The room is entered through a doorway in the stage right wall. A scaled drawing of the storage area may be seen in Figure 8, page 32. A small flat rack is provided on the left rear corner of the stage for storing flats.

DRESSING ROOMS

No dressing rooms are provided. Make-up and dressing is done in nearby classrooms and restrooms in the academic portion of the building.

LIGHTING

The heart of the lighting system is a Cutler Hammer radiastat dimmer board. The board has nine dimmers with 2,000 watts capacity each, adding to a total board capacity of 18,000 watts. There are three banks of dimmers, each mastered, and one grand master for the entire board. The dimmer board is wired direct to control borderlights and footlights. The location of the dimmer board is on the stage left proscenium wall.

There are no fresnels. There are no ellipsoidal reflector spotlights. There are two, 25 foot sections of three circuit borderlights hung above the acting area, and there are four sections of three circuit, fold away footlights. There are no floodlights. Three 1,000 watt, 8 inch plano-convex spotlights are hung in the beam position to light the forestage. They are directed through centering louvers which makes focusing or movement of the units impossible. There is one 4 inch plano-convex unit on a light stand. There are two R-40 lamps hanging from the second borderlight batten.

There are four floor pockets, all of which are on one switched circuit. There are three electrical outlets

on the face of the stage apron. Each is a double plug household receptacle. Two other electrical outlets are located in the stage area. They are both double outlet standard household receptacles and are both located on the rear stage wall. There is no electrical cable available.

SOUND

The sound system consists of a portable amplifier that is used in several locations throughout the school building. The amplifier is a Heathkit, two channel stereo unit that will run on A.C. or D.C. current. There are two speakers with the unit. A four-speed Garrard turntable is also supplied. There is no tape deck. Portable tape recorders are available from the audio-visual department when they become necessary for stage use. Two house speakers are mounted in the auditorium, and one speaker output is located on the stage left proscenium wall.

COMMUNICATIONS

No communication system is provided for stage use.

Chapter 5

GARDNER

Gardner High School is the smallest Class AAA high school in the Third Congressional District with 252 students in grades 10, 11, and 12. The school building was constructed in 1958 and is quite attractive.

AUDITORIUM HOUSE

Gardner High School is constructed with an auditorium-gymnasium combination. Space is available to seat approximately 1,600 people. The acoustics seem to be better for spectator sports than for play production.

The lobby is spacious with 1,280 square feet of space. A coat check room is provided. There is no ticket booth.

STAGE AREA

The stage at Gardner High School is of the proscenium type with the proscenium opening extending almost the full width of the stage. The proscenium opening is 74 feet. It is an open steel beam construction arching to a height of 20 feet at the center. There is no loft. There is no wing space right or left. A scaled drawing of the stage may be seen in Figure 9, page 38. The full width of

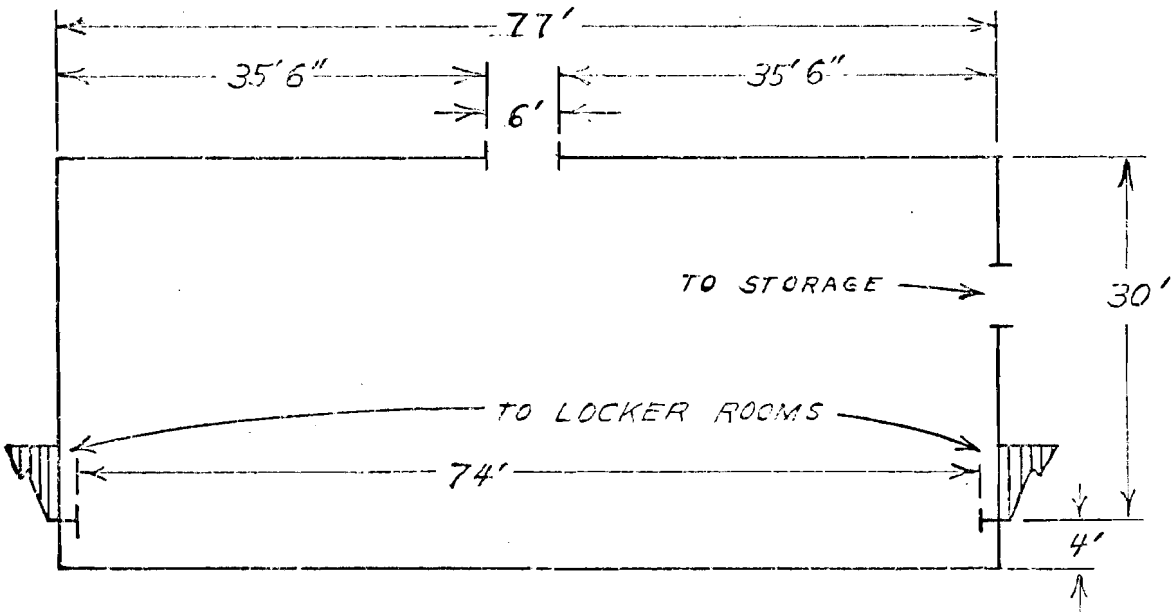

SCALE $\frac{1}{16}'' = 1'$

FIGURE 9
STAGE, GARDNER, KANSAS

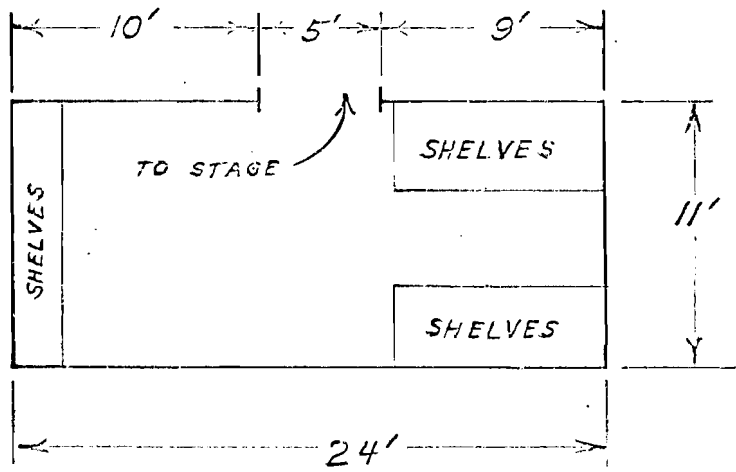

SCALE $\frac{1}{8}'' = 1'$

FIGURE 10
STORAGE ROOM, GARDNER, KANSAS

the stage is 77 feet, with 30 feet of depth from the proscenium line to the back wall. A 6 foot wide loading door to outside is located in the center of the back wall. The stage apron extends 4 feet beyond the proscenium line. The stage floor is soft pine. The floor is not trapped and there is no orchestra pit. There are no lines for moving lights or scenery. All battens are permanently hung. A door in the stage left wall leads into a storage room. A stairway is located near the proscenium wall on both stage left and stage right, leading to the locker rooms under the gymnasium bleachers, or to the gym floor.

CURTAINS AND SCENERY

The stage is equipped with a heavy cotton act curtain with returns and a matching teaser. There is a concert curtain and matching teaser. In addition to these there are three sets of black legs with matching teasers, and a pleated rear drop, also in black. There are no painted back drops and no scrim.

CONSTRUCTION AREA AND EQUIPMENT

There is no scene shop or construction area provided. All construction is done on stage or in the high school woodshop.

The Gardner High School theatre department has a good supply of tools for scenery construction. Among their supply of power tools is a circular saw, a sabre saw, an

electric drill, and an electric sander. In addition to the power tools there is an adequate supply of hand tools. Any additional tools needed are borrowed from the high school woodshop.

STORAGE AREA

The only storage provided for the Gardner High School stage is one small room off stage left. The storage room may be seen in Figure 10, page 38. A 5 foot wide door opens from the stage into the storage room. The room measures 24 feet by 11 feet, and in that 264 square feet of space is stored props, paint, hardware, costumes, lighting equipment, and all tools, power and hand. The storage room ceiling is 9 feet high. Some make-up is stored in a closet in the teacher's classroom. Many scenery pieces are stored along the back wall of the stage.

DRESSING ROOMS

No dressing rooms are provided for the Gardner High School stage. Since there are no dressing rooms, the gymnasium locker rooms are used. They are located close to the stage and there is accessibility to and from them without passing through the auditorium. In the words of the instructor, the arrangement is not satisfactory, but it does give the actors accessibility to dressing space, running water, and showers.

LIGHTING

Gardner High School stage is not equipped with a lighting dimmer board. All circuits are wired direct and are controlled by toggle switches. The only dimmer found in Gardner's inventory is a 750 watt portable dimmer that was constructed by the instructor. The inventory of lighting instruments includes ten 6 inch fresnels, supplied by Capitol Lighting, one 40 foot bank of three circuit borderlights by Capitol Stage Lighting, and four 4 inch plano-convex spotlights also supplied by Capitol. There are two 10 inch square floodlights and a Trouperette followspot. There is no beam position lighting, and there are no ellipsoidal reflector spotlights. There are ten 150 watt P.A.R. lamps with bases. The first lightpipe has a total of 30 plugs divided into 10 circuits. The stage is equipped with two floor pockets, each with a five plug capacity. The floor pockets are on two circuits. There are five household type electrical receptacles around the stage walls.

The inventory also includes 120 feet of electrical stage cable and approximately 500 feet of heavy duty drop-cord.

SOUND

The sound system wired into the stage is for the purpose of public address, and for theatre sound effects. The amplifier is located in the main office of the school

and the system is wired through the building. The stage is equipped with six microphone pick-ups. Five are located along the stage apron and the sixth is in the center stage floor. The house speakers are those used for public address at athletic events. There are seven speakers mounted around the walls of the gymnasium. No provision is made for the production of electronic sound effects.

COMMUNICATIONS

A communication system is provided which allows audio contact between the following areas: stage manager's area, stage right, stage left, and the lobby.

Chapter 6

LYONS

Lyons High School is the smallest Class AAA high school in the Fourth Congressional District. The total enrollment in grades 10, 11, and 12 is 270 students.

AUDITORIUM HOUSE

The high school and auditorium at Lyons, Kansas were constructed in 1969. The auditorium is a large fan-shaped structure designed to seat 1,200 people. There is no balcony. The seating is divided into three areas with two center aisles and two side aisles. An 8 foot wide aisle at the rear of the seating reaches the full width of the auditorium allowing ease of movement from one seating section to another. A floor plan of the auditorium may be seen in Figure 11, page 44. The auditorium fans from a proscenium width of 50 feet to a width of 155 feet at the rear. The depth of the auditorium from the proscenium line to the rear wall is 155 feet. A concrete floor slopes from back to front with turquoise carpeting stretching the length of the aisles. The walls are of dark brick. There are no windows.

A sound booth is located at the rear of the center section of seating. A projection and spotlight room is located above the sound booth.

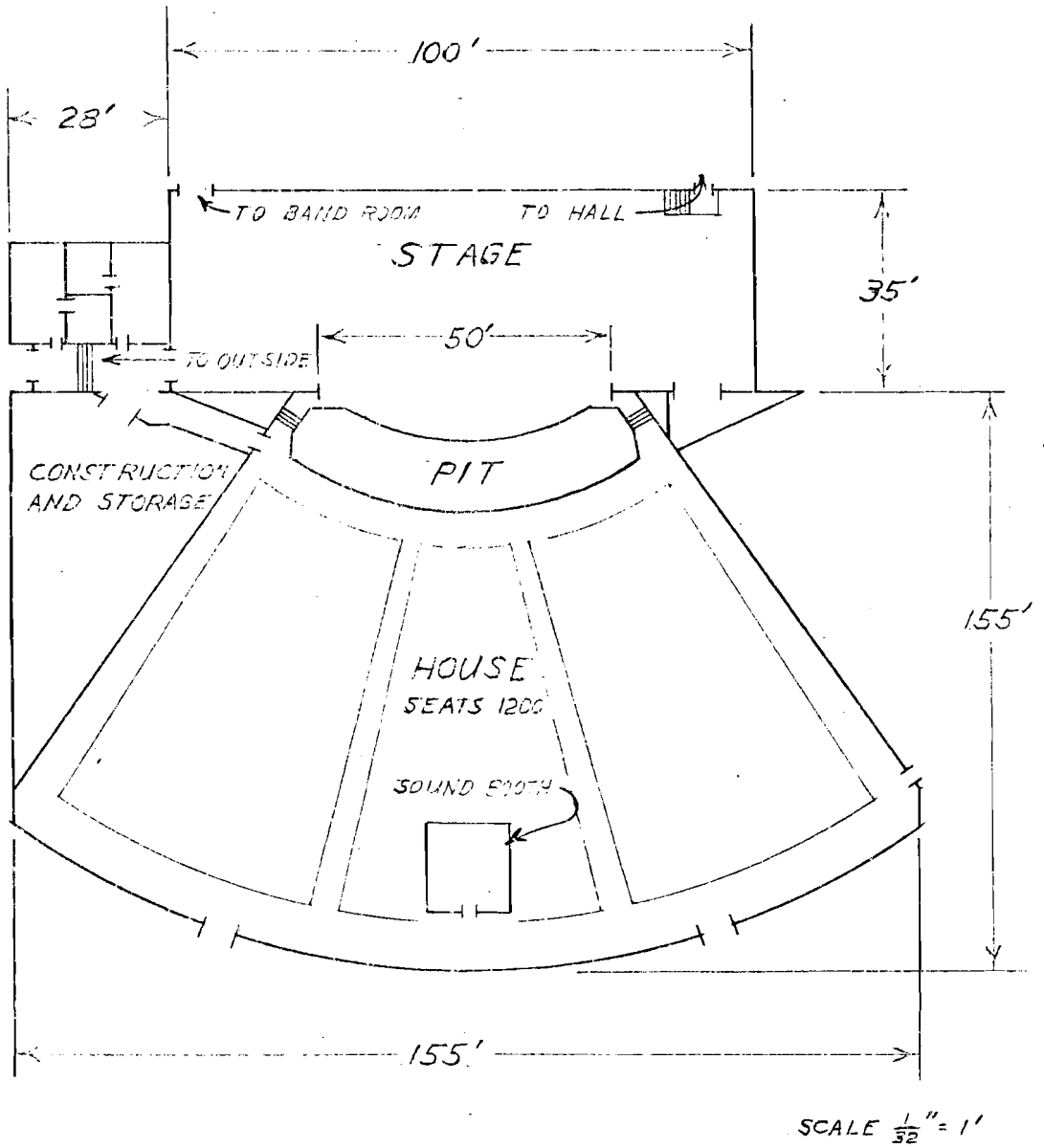

FIGURE 11

THEATRE PLANT, LYONS, KANSAS

One doorway in the left auditorium wall leads to the backstage area and to outside. Two large double doors lead from the back of the auditorium into the lobby.

The structure is designed to accommodate both auditorium and gymnasium crowds in a common lobby. The lobby is large, consisting of nearly 4,000 square feet. It is also designed to open into the high school cafeteria which is attractive and equipped to serve as additional lobby space, smoking quarters, and refreshment area. Six pair of double doors lead from the lobby to the outside parking area.

There is no ticket booth, and there is no coat check.

STAGE AREA

The stage at Lyons High School is a proscenium stage. The proscenium opening measures 50 feet in width and 20 feet in height. The full width of the stage is 100 feet with 35 feet of depth from the proscenium line to the rear stage wall. Scaled drawings of the stage area may be seen in Figures 11 and 12, on pages 44 and 46.

The wing space stage left and stage right are identical. Each measures 25 feet by 35 feet, providing a total wing area of 1,770 square feet. The stage is equipped with a full loft to the height of 50 feet. Twenty-six counterweighted lines are provided. There are no dead lines. One winch motor is supplied to assist in moving unbalanced lines.

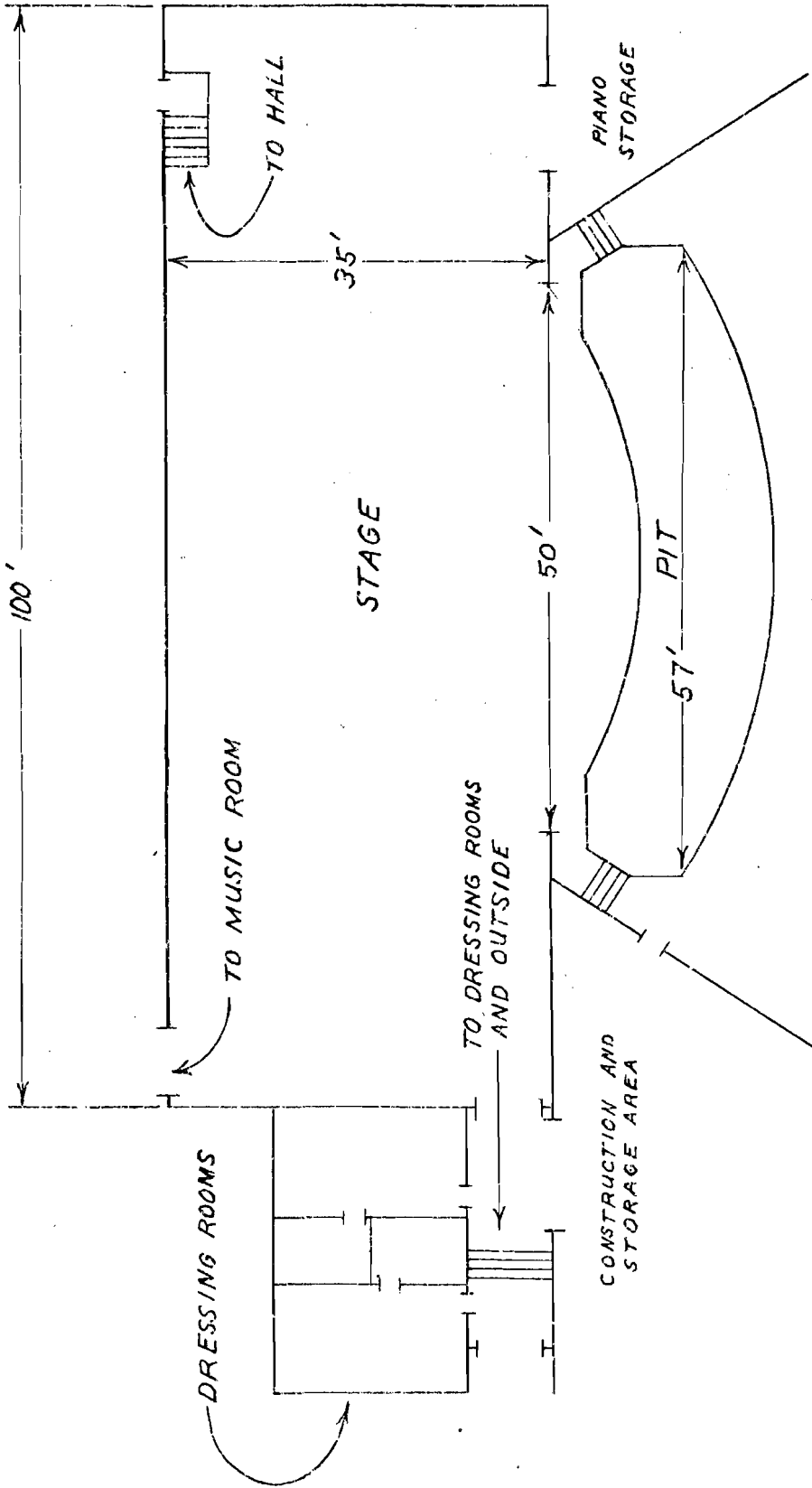

SCALE $\frac{1}{8}'' = 1'$

FIGURE 12
STAGE, LYONS, KANSAS

The stage floor is covered partly in hard wood, part in soft wood, and partly in cement. The wing areas stage left and stage right are concrete. The acting area is of soft wood from the back stage wall to the concert curtain line, a distance of 25 feet 6 inches. A polished hard wood is provided from the concert curtain line across the stage apron. The apron extends 8 feet 6 inches beyond the proscenium line. The stage floor is not trapped. There is an orchestra pit, making a distance of 18 feet from the front row of seats to the stage apron.

A double door in the stage left proscenium wall opens into a piano storage room designed to house a 9 foot grand piano. In the stage left rear wall a door opens into a hallway to other parts of the building. A double door in the rear wall, stage right, leads into the high school band room. A large double door in the stage right wall leads to the storage-construction area, the dressing rooms, and to outside.

CURTAINS AND SCENERY

The Lyons High School stage is equipped with a turquoise colored cotton act curtain. There is a teaser and a pair of returns to match. There is a gold cotton concert curtain, also with a matching teaser. Two pleated travel curtains are provided for rear masking. They are of a charcoal gray color and are matched by four pairs of legs and four teasers. All curtains are of cotton material, and all are lined.

The stage is also equipped with a blue stretched sky cyclorama. The cyclorama measures 50 feet in width by 21 feet 3 inches in height. It is a straight cyclorama and is used only as a rear cyclorama in conjunction with teasers and legs. A seamless sharks-tooth scrim is also provided. The scrim measures 50 feet by 22 feet. There are no painted backdrops.

CONSTRUCTION AREA AND EQUIPMENT

The construction and storage area is a triangular shaped room and may be seen in Figures 11 and 13, pages 44 and 49. It measures 68 feet on its longest side and has a maximum width of 48 feet. The square footage of the construction-storage area is approximately 1,630 square feet. The construction area is conveniently accessible to the stage and to the outside. The ceiling height of the construction area is 30 feet. Because of the spaciousness of the stage, the construction area is used primarily for storage of scenery, props, and supplies, and most all of the construction is done on stage.

A few assorted hand tools belong to the theatre department. In addition to the hand tools there is a one-fourth inch electric drill and an electric sabre saw. When the tool supply becomes inadequate to complete any construction task, additional tools are borrowed from the high school woodshop. Construction pieces requiring the use of large power tools are completed in the woodshop.

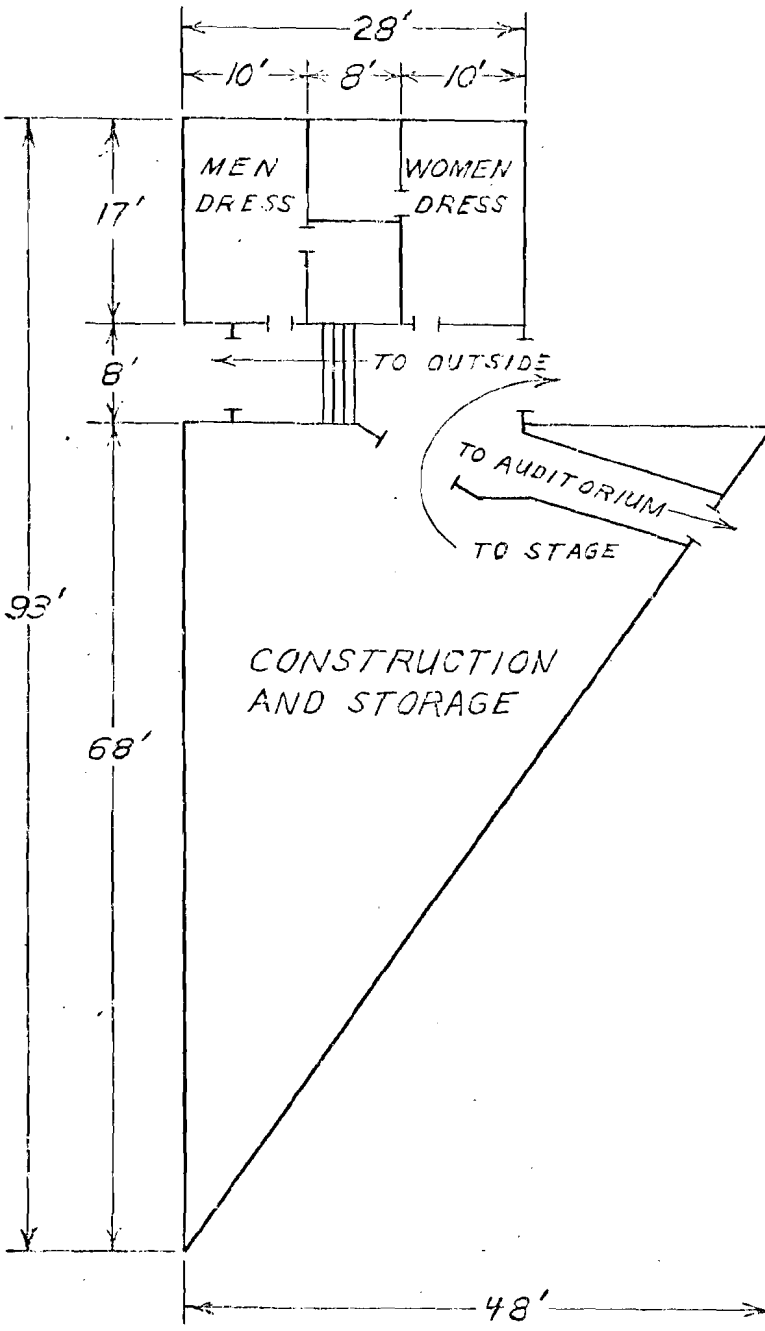

SCALE $\frac{1}{16}'' = 1'$

FIGURE 13

CONSTRUCTION AND DRESSING ROOMS
LYONS, KANSAS

STORAGE SPACE

The auditorium at Lyons High School is designed with construction and storage being one in the same area. The space described above is provided for both construction and storage. There are no shelves, cabinets, or bins provided in the storage area, so at present the equipment and supplies are grouped and stacked along the walls of the room. Flats are stored on stage. There is no flat rack. Make-up is stored in the drama instructor's office.

DRESSING ROOMS

The dressing rooms at Lyons High School are located very near the stage on the stage right side. A scaled drawing of the dressing rooms may be seen in Figure 13, page 49. The location of the dressing rooms to the stage may be seen in Figure 12, page 46. The two dressing rooms are identical, each measuring 17 feet by 10 feet. Each is equipped with a restroom with hot and cold running water. A make-up table reaches the length of one wall in each room, and is equipped with six individual make-up mirrors. The lighting is florescent. The number of electrical outlets is adequate. There are no showers. As dressing rooms the rooms are most attractive and functional.

LIGHTING

Lyons High School stage is equipped with a rheostat dimming board supplied by Hub Electronics. There are

12 dimmers on the board each with the capacity of 3,600 watts. The total dimming capacity of the board is 47,000 watts. The board is located on the stage right wall.

Lyons High School lighting equipment inventory includes eight 6 inch fresnels, nine 8 inch ellipsoidal reflector spotlights, four 6 inch plano-convex spotlights, four 4 inch plano-convex spotlights, four 14 inch floodlights, and four banks of three circuit borderlights, totaling 140 feet. In addition to the inventory listed there are three 10 foot sections of three circuit portable strip units, eight 6 inch seal beam spotlights, and four 8 inch sealed beam spotlights. All of the equipment listed, with the exception of the seal beam units are supplied by Capitol. The sealed beam units are supplied by Ariel Davis. There is no followspot.

The first light pipe is equipped with 20 outlets divided into 10 circuits. There are eight electrical floor pockets located around the acting area, and 12 electrical outlets in the orchestra pit. Three additional outlets are located on the stage right, and three on the stage left walls. There is no electrical cable available with the exception of a few feet of dropcord.

SOUND

The sound booth is located at the back of the auditorium. A sliding glass window is provided for viewing

the stage and monitoring the house speakers. A five circuit amplifier with a 120 watt capacity is supplied by DuKane. There is neither turntable nor tape deck provided. Four house speakers are supplied and are hung on the stage right and stage left proscenium walls. There are six microphone pick-ups located on stage. Three are in the stage floor across the front of the stage, and three are hanging from the first light pipe.

The microphones used are four DuKane Model 7A810, and two Electrovoice 7A295.

The acoustics of the auditorium are such that the sound system need not be used to amplify voices during play production.

COMMUNICATIONS

A communication system is provided that allows verbal contact among people at the following positions: Light board, sound booth, stage manager area, stage right, stage left, and followspot position.

Chapter 7

NEODESHA

Neodesha High School is the smallest Class AAA high school in the Fifth Congressional District. The total enrollment in grades 10, 11, and 12 is 223 students.

AUDITORIUM HOUSE

The auditorium at Neodesha High School is not part of the original school building. A separate building was constructed in 1950 to serve as a gymnasium-auditorium combination. The gymnasium is standard high school basketball playing floor size with bleachers running full length of the court on both sides. Large windows line both side walls of the structure. The gymnasium is attractive and in excellent repair.

At the rear of the gymnasium three large 6 feet 2 inch wide doors lead into a large lobby. The lobby measures 42 feet long by 22 feet, 3 inches, providing a total of 925.05 square feet of space. Two large double doors measuring 5 feet 7 inches in width lead to outside. There is neither ticket booth nor coat check.

STAGE AREA

The stage is a proscenium type stage with a proscenium opening measuring 40 feet in width and 17 feet

9 inches in height. The full stage measurement is 64 feet wide by 23 feet deep. A 6 foot wide loading door is located in the center of the rear stage wall. A floor plan of the stage may be seen in Figure 14, page 55. The stage right and stage left wing areas are identical, each allowing 276 square feet of space, for a total of 552 square feet of wing space. There is no loft. There are no fly lines. All light and scenery battens are permanently hung. The stage floor is of hard wood and it is not trapped. A 3 foot door is located in both the stage right and stage left walls leading into storage rooms.

CURTAINS AND SCENERY

Neodesha High School auditorium is equipped with a velour act curtain. The curtain was supplied with returns and with two matching teasers. Side and rear masking is achieved by a cotton, pleated cyclorama in a gray color. It was supplied with two matching teasers. A gold cotton concert curtain is also provided. There is no stretched sky cyclorama. There are no painted back drops. There is no scrim.

CONSTRUCTION AREA AND EQUIPMENT

The stage is not equipped with a scene shop or a construction area of any kind. All construction is done on stage, or in the high school woodshop.

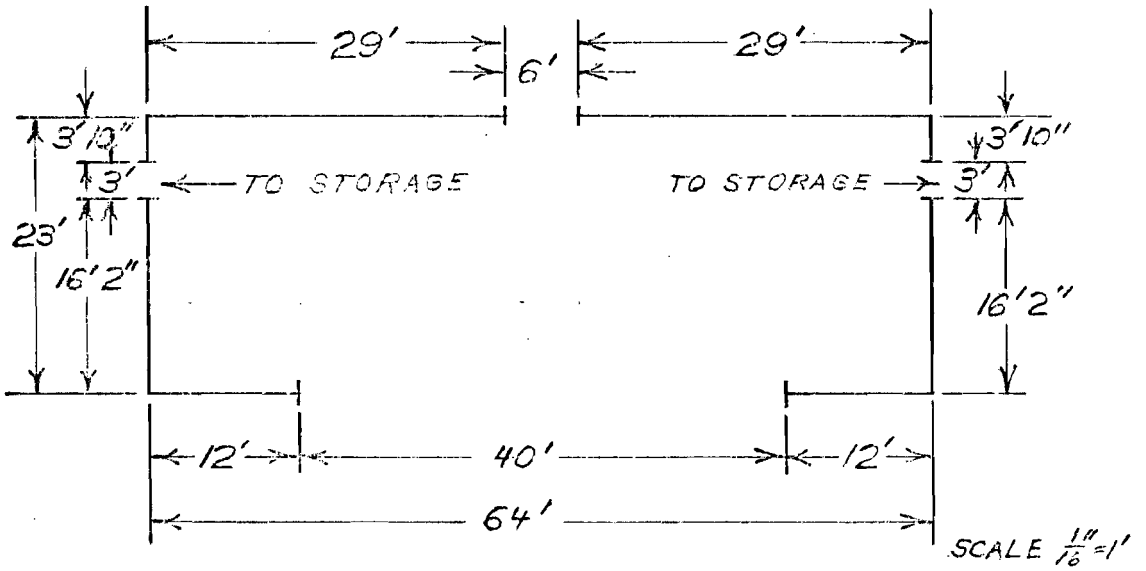

FIGURE 14
STAGE, NEODESHA, KANSAS

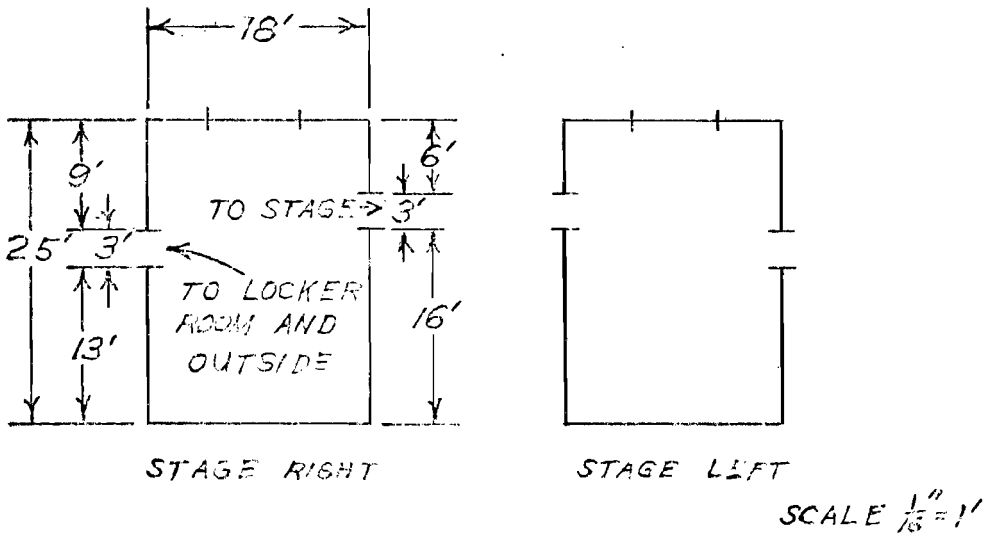

FIGURE 15
IDENTICAL STORAGE ROOMS, NEODESHA, KANSAS

There are no hand or power tools in the theatre inventory. All tools needed for construction are borrowed from the school woodshop.

STORAGE SPACE

Two rooms are provided for storage, one located on either side of the stage. A floor plan of the two storage rooms may be seen in Figure 15, page 55. The two rooms are identical, both measuring 18 feet by 25 feet. The two storage rooms combined total 900 square feet of storage space. The ceiling height is 11 feet. Each room has an escape door which leads into a hallway to the gymnasium floor, to the locker rooms below the gymnasium bleachers, or to the outside. Each store room is designed with one large window in the rear wall. The storage space described also doubles as dressing room space.

In addition to the two storage rooms, some space is available under the stage floor for storage. The area is accessible from the gymnasium floor in front of the stage apron and is used primarily for the storage of metal folding chairs on roll-in racks. Some of the under stage is available for storage of lumber stock.

A few costumes and a limited supply of make-up is stored in a closet in the speech and drama classroom.

DRESSING ROOMS

No dressing rooms are provided in the Neodesha High School theatre plan. The storage rooms located stage

left and stage right described above must double as dressing room space. Restroom facilities and running water are available in the athletic locker rooms nearby. The locker rooms are accessible from the stage area without passing through the auditorium house.

LIGHTING

There is no light dimming system provided for the Neodesha High School stage. All circuits are wired and controlled by toggle switches. There is no beam position lighting. There are no fresnels. There are no ellipsoidal reflector spotlights. Stage lighting is achieved by ten 4 inch plano-convex spotlights located on the first light pipe, and two banks of borderlights. The borderlights are three circuit units with color glass rondels. The first light pipe is equipped with 12 pin connector pig tails, divided into six switched circuits. There are no floodlights, and there is no followspot.

The stage is not equipped with electrical floor pockets. The only outlets available in the stage area are three, double household receptacles located on the down stage left apron, and two other double household receptacles, one located on the stage left, the other on the stage right wall.

SOUND

The sound equipment is located in the stage right wing area. It consists of a 200 watt four circuit Bogen

amplifier, and a three-speed R.C.A. turntable. A tape deck is not supplied. A tape recorder from the classroom is sometimes used. There are two microphone pickups located on stage, one in the stage left, one in the stage right apron. There are four speakers located in the gymnasium-auditorium. The sound system also includes an Electrovoice Dynamic 639 microphone, an Electrovoice Sound Spot 644 microphone, and 75 feet of microphone extension cable. The sound system is used only for public address and is not used for play production.

COMMUNICATIONS

No communication system is provided for use in play production.

Chapter 8

OTTAWA

Ottawa High School represents the largest high school in the Third Congressional District, with a net enrollment of 600 students in grades 10, 11, and 12. The Ottawa High School building was constructed in 1965, but the structure does not include an auditorium. All high school productions are produced in Ottawa's city auditorium for which the high school district pays rent. Therefore the equipment and facilities described in this writing are not the property of the school district, but are only available to the high school drama department for use. The facility is also used for various functions by the city of Ottawa, and on occasion by Ottawa University.

AUDITORIUM HOUSE

The city auditorium was constructed in 1919. The structure consists of an auditorium with a balcony, a stage with a complete loft, understage dressing rooms, and various other small meeting rooms. A floor plan of the auditorium may be seen in Figure 16, page 60. The auditorium measures 75 feet 6 inches from the proscenium line to the back wall, with a width of 71 feet 4 inches. A horse-shoe shaped balcony reaching from one proscenium

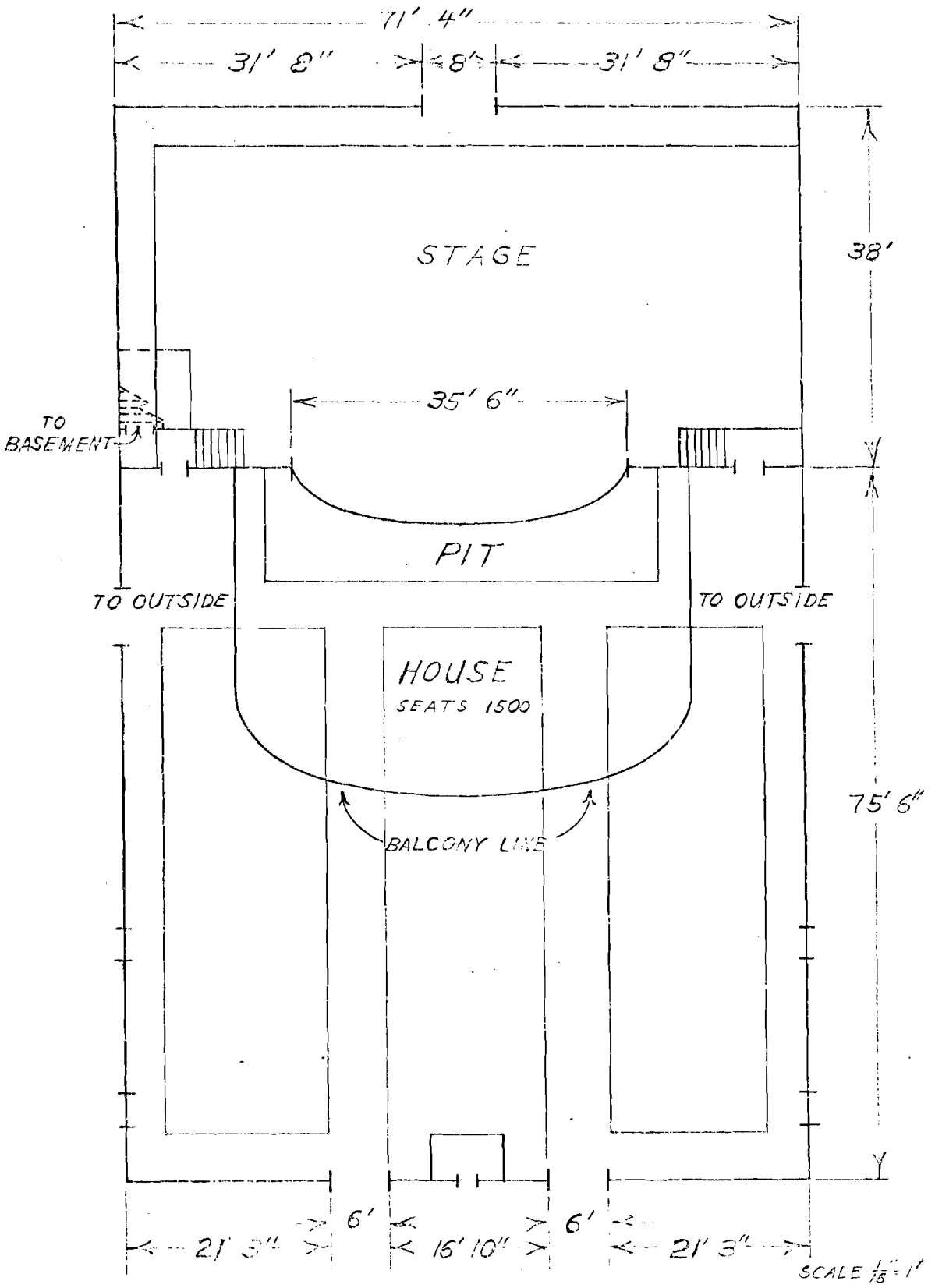

FIGURE 16

AUDITORIUM HOUSE, OTTAWA, KANSAS

wall to the other curves 34 feet 9 inches into the house. The total seating capacity is 1,500 people. The auditorium seats are divided into three sections by two aisles. Windows are designed into the auditorium walls near the back and exit doors are provided near the front.

The lobby measures 34 feet 8 inches by 14 feet 8 inches providing 481.33 square feet of space. Two large 6 foot wide doors lead to outside. Restrooms are available. There is a ticket booth, but there is no coat check.

STAGE AREA

The stage is a proscenium stage with a proscenium opening measuring 35 feet 6 inches. The proscenium height is 24 feet. The full stage measures 71 feet 4 inches by 38 feet. A scaled drawing of the stage may be seen in Figure 16, page 60. A full loft of 50 feet is provided. The wing space stage left and stage right is identical, each measuring 17 feet 8 inches by 38 feet. The total wing area equals 1,342.66 square feet of space. The floor covering material is hard maple. One trap measuring 2 feet 9 inches by 5 feet 5 inches is located center stage and opens into the basement. A large 8 foot wide loading door is located in the center of the rear wall. There are 26 fly lines, none of which are counterweighted. They are tied off at a pin rail located 25 feet above the stage floor. A catwalk at that height is the location from which the lines are operated, and from where sand bags may be tied onto the lines when weight assistance becomes necessary.

An orchestra pit is provided and is partially covered by the stage apron which curves to a distance of 5 feet 10 inches beyond the proscenium line. The distance from the first row of seats to the apron is 10 feet 10 inches.

CURTAINS AND SCENERY

The Ottawa city auditorium is equipped with a velour act curtain. There are four pairs of dark velour legs and three dark teasers. There is one dark velour pleated traveler curtain. In addition to the velour curtains, there is one light colored cotton traveler curtain with two cotton teasers and two pairs of cotton legs to match. All curtains are lined. There are no painted backdrops.

CONSTRUCTION AREA AND EQUIPMENT

The Ottawa city auditorium was not designed with an area for construction. All construction is done on stage. Materials may be moved in and with ease through an 8 foot side loading door in the center of the rear stage wall.

Ottawa High School drama department does not own any hand tools. Borrowing tools from the high school woodshop is impractical because of the distance from the school woodshop to the city auditorium. Therefore students bring tools from home to accomplish the construction, and then

take them home again after strike. Power tools are at a premium. The drama department has a sabre saw and an electric drill.

STORAGE AREA

There is no storage space provided in the Ottawa city auditorium. All scenery pieces stored at the auditorium are stacked in the rear corners and along the back wall of the stage. The only other storage area is a small closet in the instructor's classroom in which a few props are stored, a few pieces of stage hardware, and a limited supply of theatrical make-up. There is no storage for paints, and paint is therefore not kept on hand. A few costumes are kept and stored in boxes in the cafeteria area store room with food commodities.

DRESSING ROOMS

The basement area under the stage is designed to be used as dressing rooms. The dressing rooms are close to the stage, and restroom facilities are available. A floor-plan of the dressing room area may be seen in Figure 17, page 64. There are seven rooms available. Hot and cold water is available from one lavatory in each room and from the restrooms. There are no make-up tables, no mirrors, no showers, and the lighting is very poor. The space appears to be unacceptable as a dressing area in its present condition. The high school drama department uses two rooms for dressing, and two rooms for make-up.

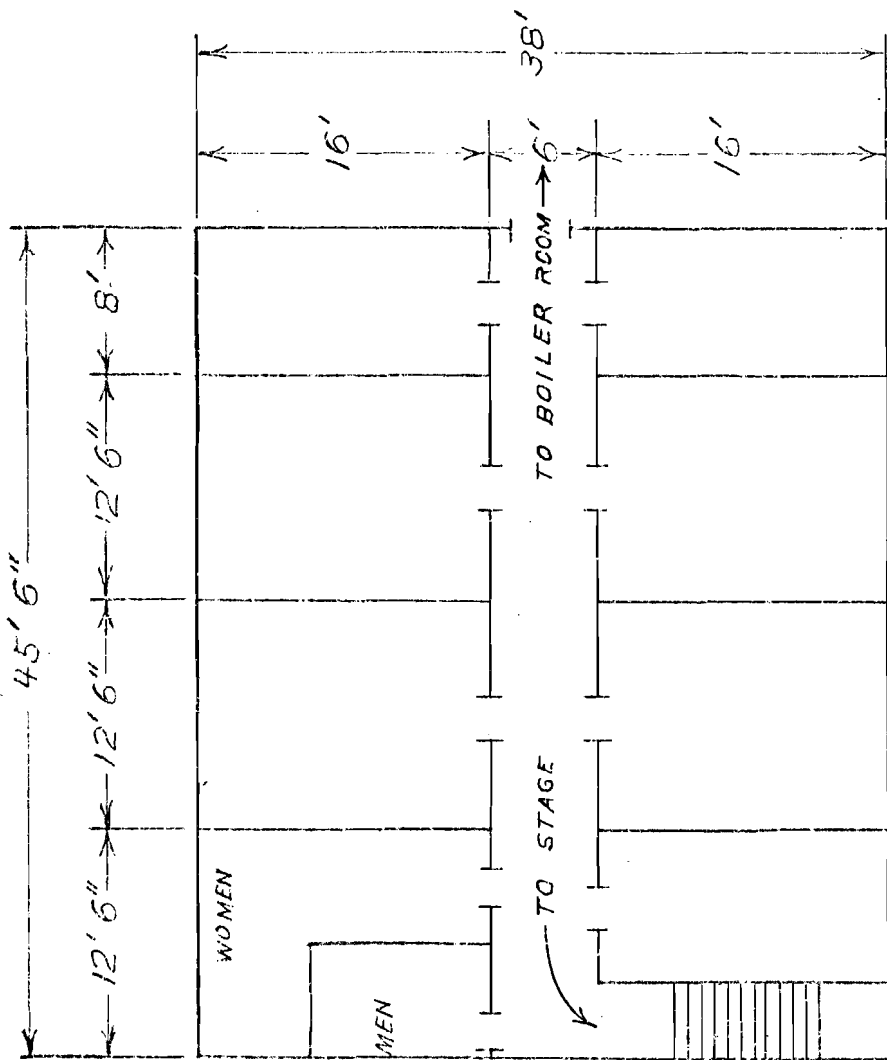

SCALE $\frac{3}{32}'' = 1'$

FIGURE 17
DRESSING ROOMS UNDER STAGE, OTTAWA, KANSAS

LIGHTING

The stage is equipped with a portable Ward Leonard rheostat dimmer board. The board has six circuits with a total capacity of 15,000 watts. Productions are lighted by running electrical cable from the portable board to the location of each instrument. Neither the auditorium nor the school drama department own any lighting instruments. All instruments are borrowed or rented from Ottawa University, or from an agency in Kansas City, Missouri. The theatre is equipped with two banks of borderlights and a trough of footlights, all of which are on switched circuits. The high school does have possession of two Trouperette follow-spots in shared ownership with the junior high school. The stage floor is equipped with three floor packets all of which receive four standard household type plugs. There are ten household type outlets in the orchestra pit.

SOUND

There is no sound system provided. When special sound equipment is needed it is rented for use in a particular show. The high school does have portable record players and tape recorders that may be used.

COMMUNICATIONS

The building is not equipped with a communication system. The high school has at its disposal a portable

intercom system which can be hooked up and used for communication during the run of a show. The system allows communication from the stage manager to the light board, the followspot, and the orchestra pit.

Chapter 9

PARSONS

Parsons High School represents the largest Class AAA high school in the Fifth Congressional District. The enrollment is 610 students in grades 10, 11, and 12. Parson's high school building was constructed in 1954.

AUDITORIUM HOUSE

The auditorium at Parsons High School was constructed in 1954. The seating is traditional with two aisles dividing the seating into three sections. The seating capacity is 572 people. A floor plan of the auditorium may be seen in Figure 18, page 68. There is no balcony. The auditorium measures 87 feet from the proscenium line to the back wall. The width at the back is 57 feet and narrows to 47 feet 10 inches at the front. A group of tall narrow windows are designed into the outside wall. The auditorium is pleasingly decorated and in excellent repair.

At the rear of the auditorium two 4 foot 6 inch doors open into a spacious lobby of 1,817 square feet of space. The lobby adjoins hallways leading to the rest of the building. Two double doors lead outside and to the parking area.

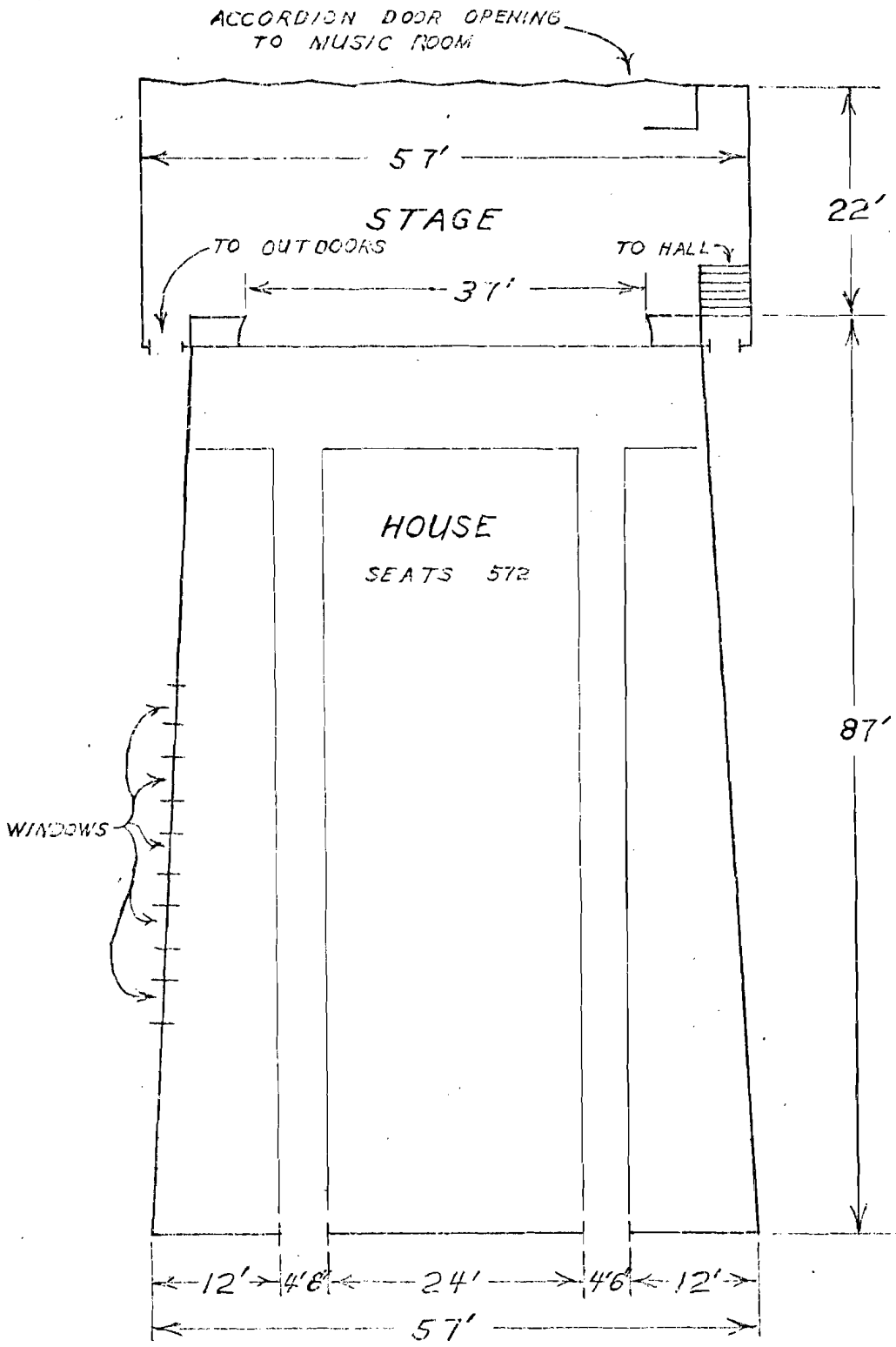

SCALE $\frac{1}{16}'' = 1'$

FIGURE 18

AUDITORIUM HOUSE, PARSONS, KANSAS

STAGE AREA

The stage at Parsons High School is a proscenium type stage with a proscenium opening measuring 37 feet. The height of the proscenium opening measures 13 feet 4 inches. There is no loft. The wing area is 170 square feet on the stage left side and 220 square feet on the stage right side, making a total of 390 square feet of wing area. There are no fly lines. All lighting and scenery battens are permanently hung. The floor covering material is hard oak. The stage floor is not trapped, and there is no orchestra pit. The distance from the first row of seats to the apron measures 9 feet 5 inches. A scaled drawing of the stage may be seen in Figure 18, page 68. The total width of the stage is 57 feet, with a depth measuring only 22 feet. The rear wall of the stage is a folding door construction which may be opened into the high school music room. There is 46 feet of usable space behind the accordion door making a possible stage depth of 68 feet. The stage may be exited through two doorways, each located in the extreme right and left corners of the down stage wall. The stage right doorway exits to outdoors. The stage left doorway exits into an interior hallway connecting to the rest of the school building.

CURTAINS AND SCENERY

The Parsons High School stage is equipped with an act curtain. The curtain material is cotton. There is a

pair of returns and two matching teasers. A gold cotton concert curtain is also provided. Side and rear masking is achieved by a pleated cotton cyclorama. The cyclorama is in a tan color with red and green specks. Two teasers are supplied to match the cyclorama. There is one professionally painted foliage backdrop. There is no scrim.

CONSTRUCTION AREA AND EQUIPMENT

The stage at Parsons High School is not equipped with a scene shop or construction area of any kind. All construction is done on stage or in the high school woodshop.

The drama department does own a few assorted hand tools, but not nearly enough to accomplish set construction. The majority of tools, both hand and power must be used from the high school woodshop.

STORAGE SPACE

Other than the stage floor itself, there is no storage space provided. A limited supply of make-up is stored in a classroom closet, and the drama hand tools are stored in a metal tool chest and locked in the high school vault.

DRESSING ROOMS

There are no dressing rooms provided. Costume changes and the application of make-up are accomplished in

the music department practice rooms. Running water is not available, but the rooms are in a convenient location to the stage.

LIGHTING

The Parsons High School stage is equipped with a Metropolitan, Lumi-Tron dimmer board. The board is equipped with eight dimmers and three masters. The capacity of each dimmer is 2,000 watts totaling 16,000 watts. The dimmer board is located on the stage left proscenium wall.

The beam position lighting is accomplished by ten P.A.R. units at 150 watts each. The lighting inventory includes four 6 inch fresnels. They are plugged into adapter outlets that have been put in place of lamps removed from the borderlight troughs. There are no ellipsoidal reflector spotlights. The stage is equipped with borderlights. There are six 8 foot long units, all in four circuits. Five units of footlights are also provided in four circuits. All borderlights and footlights are colored with glass rondels. There is no followspot available.

Three floor pockets are provided in the stage floor. Each is equipped with three outlets. Other than the floor pockets there is one electrical outlet located inside the stage left proscenium wall. It is a three outlet household receptacle. There are no outlets in the area directly in front of the stage apron.

SOUND

The auditorium is not equipped with a sound system. Record players and tape recorders are available for use from the classroom when they become necessary. Since an amplifier is not provided, there are neither microphone pick-ups in the stage area, nor are there speakers in the auditorium.

COMMUNICATIONS

A communication system is not provided.

Chapter 10

ST. JOSEPH'S -- HAYS

St. Joseph's at Hays is the largest Class AAA high school in the First Congressional District. The total enrollment in grades 10, 11, and 12 was 851 students at the time of this study.

St. Joseph's theatre department is in the process of drastic change. The department has been inactive for a period of eight years, a period in which the auditorium was not used for dramatic production. An instructor has recently been assigned to St. Joseph's who is in the process of rejuvenating the theatre and the department. Much of the equipment described in this writing has recently been purchased from closing theatres and from army surplus. Much of the equipment is in dire need of repair before it will be functional.

AUDITORIUM HOUSE

The auditorium was constructed in 1931. It was designed and constructed in such a manner that the stage area would serve as a basketball playing court as well as a production stage. The same auditorium house was utilized to accommodate a theatre audience or a sporting event audience. The auditorium is a rectangular shape measuring 83 feet 4 inches wide and 46 feet 6 inches deep. The

seating capacity is 851 with about one-third of the seating being balcony seats. A scaled drawing of the St. Joseph's auditorium may be seen in Figure 19, page 75. Both sides of the auditorium are lined with large windows on both the ground and balcony levels. The entire structure is in desperate need of repair and decoration.

The lobby consists of a large ten foot wide terrazzo hallway that connects the auditorium to all parts of the school building. Restrooms are available in the hall lobby. There is a ticket booth, but there is no coat check.

STAGE AREA

The stage is a proscenium type with a large proscenium opening extending to nearly the complete width of the stage. The stage width is 65 feet and the proscenium opening measures 63 feet. The height of the proscenium opening is 16 feet. The stage depth is 40 feet. The stage was designed to serve not only as a production stage, but also as a basketball court. The lines and circles of the court are still visible on the hard maple floor. Since the construction of a gymnasium a few years ago the stage is no longer used for gymnasium purposes. The stage has a very shallow loft of 22 feet. There are two counterweighted lines to handle the two strips of borderlights, and seven dead lines for moving curtains and scenery. There is no wing space on stage left or

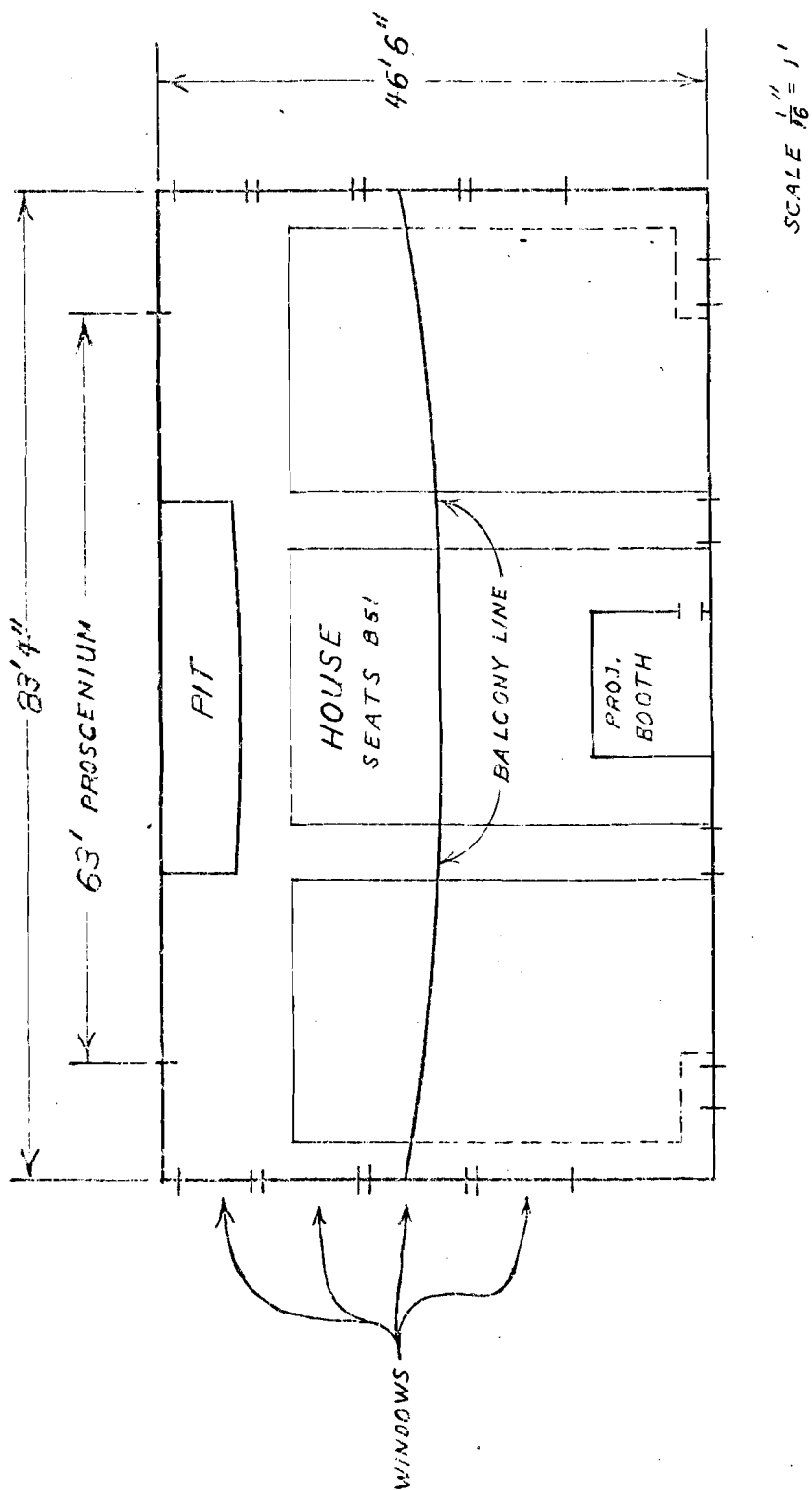

FIGURE 19
AUDITORIUM, ST. JOSEPH'S, HAYS, KANSAS

stage right. A floor plan of the stage may be seen in Figure 20, page 77. Large windows line the rear stage wall. They have been painted to reduce the amount of light entering the stage area. A stage right passageway leads from the stage to a hallway, and a door stage left opens into a large store room. An apron extends 6 feet from the proscenium line to its edge where a shallow orchestra pit is provided. A drawing of the orchestra pit may be seen in Figure 19, page 75. The distance from the front row of seats to the apron is 12 feet. The stage floor is not trapped.

CURTAINS AND SCENERY

St. Joseph's auditorium is equipped with an act curtain of dark blue velour. There are no returns or matching teasers. The curtain is lined. All other curtains and scenery were not purchased pieces, but were constructed from canvas and muslin by the department. There are three pairs of canvas white legs with one matching teaser. There is one dark green canvas traveler with two pairs of matching legs. There is one dark red canvas drop, and two black canvas teasers. None of these pieces are pleated or lined. There is a white canvas sky cyclorama rigged on a rollup batten. On another rollup batten is a student painted foliage backdrop. There is no scrim.

SCALE $\frac{1}{16}'' = 1'$

FIGURE 20
STAGE, ST. JOSEPH'S, HAYS, KANSAS

SCALE $\frac{1}{16}'' = 1'$

FIGURE 21
STORAGE, ST. JOSEPH'S, HAYS, KANSAS

CONSTRUCTION AREA AND EQUIPMENT

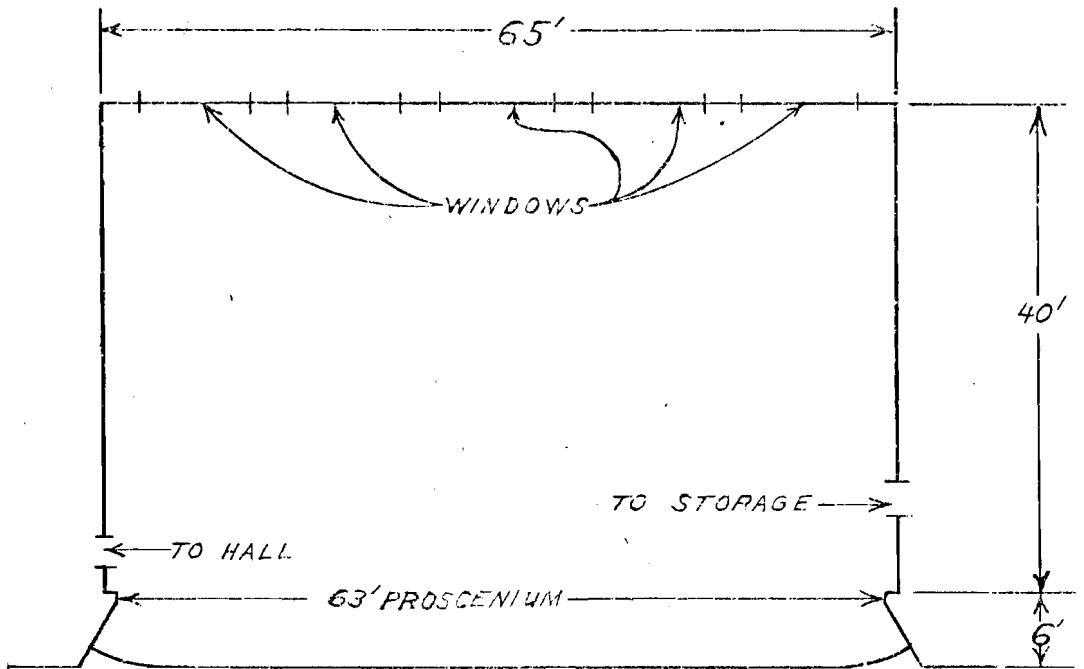
The structure is not equipped with a scene shop for construction. Construction is done on stage. Because of the stage size, ample room is available. Until one year ago, St. Joseph's theatre department did not own any tools, hand or power, and all tools needed were borrowed from the school woodshop. Special construction items could also be constructed in the woodshop. Within the last year St. Joseph's has discontinued all woodworking classes and the woodshop has been abandoned making the entire area and all of its supplies available to the drama department. The woodshop area measures 50 feet by 30 feet with an 11 foot ceiling. It is completely equipped with all power and hand tools necessary for scenery construction. The woodshop is in a basement area and is not conveniently located to the stage. The area has a dingy dark atmosphere and would not be pleasant for work without decoration.

STORAGE AREA

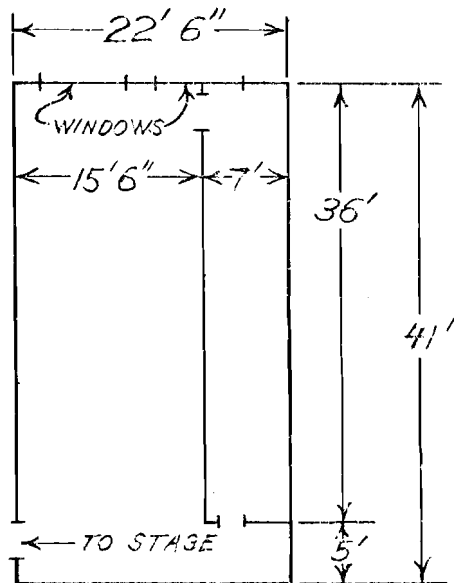
A large room measuring 41 feet by 22 feet 6 inches is located on the stage left side of the stage. The room was originally constructed as a locker room and shower room for use when the stage floor was used as a basketball court. A portion of the room is partitioned and is used for costume storage. A scaled drawing of the storage room may be seen in Figure 21, page 77. Another storage room is also in use by St. Joseph's theatre department. It

measures 22 feet by 10 feet, with a 12 foot ceiling. It is located in an area away from the stage and is used for storage of props and items that are not often used. There is no flat rack on stage. Flats are stood against the back wall for storage.

DRESSING ROOMS

St. Joseph's auditorium was not equipped with theatre dressing rooms. At the present time the storage room is used for a dressing and make-up room, and when necessary, nearby classrooms and restrooms may be used.

LIGHTING

The original equipment for the theatre did not include a dimmer system. All circuits were switched. A used dimmer board had just been purchased at the time of this study, but it was not yet installed. The board is a Cutter Hammer radiastat board with 14 dimming circuits. The capacity is 2,400 watts per dimmer. The dimmers are banked into three sections, each mastered. There is one grand master for the entire board. The board is to be installed on the stage right wall.

The theatre was equipped at the time of construction with two 42 foot sections of borderlights. They are three circuit strips, designed to accept standard medium base type "A" light bulbs. Footlights are also provided in three circuits and are also designed to accept type "A" light bulbs.

Other lighting equipment includes ten R-40 units with color clips, seven 4 inch fresnels with globular lamps, two 6 inch fresnels, one 6 inch ellipsoidal reflector spotlight, one 4 inch plano-convex spotlight, one 3 inch plano-convex spotlight, and six light stands. There are no floodlights and there is no followspot.

The stage is not equipped with beam position lighting, and the only stage lighting is from the border-lights and footlights. There are no electrical floor pockets, but two four outlet, three-wire twist lock plugs have recently been installed in the footlight trough. There are four other electrical outlets located on stage. They are standard household type outlets and two are located on the stage right wall, two on the stage left wall. There are seven double household outlets located in the orchestra pit.

SOUND

A sound booth is not provided in the auditorium. There is an amplifier provided for stage use and kept on the stage on a roll-about cart. The amplifier is supplied by "Knight" and is equipped with pot keys for phonograph and tape deck control. It is designed with four mike circuits. There is no turntable or tape deck with the amplifier. There are no microphone pick-ups located on stage and there are no house speakers.

COMMUNICATIONS

No communication system is provided.

Chapter 11

TONGANOXIE

Tonganoxie represents the smallest Class AAA high school enrollment in the Second Congressional District. The auditorium and school building was constructed in 1965. The net enrollment in the upper three grades is 246 students.

AUDITORIUM HOUSE

The auditorium was constructed in 1965, at the same time that the school building was constructed. The auditorium length is 96 feet 6 inches from the proscenium arch to the back wall. The width of the auditorium is 56 feet at the back and 47 feet at the front. A detailed drawing of the auditorium house and stage may be seen in Figure 22 on page 83.

The auditorium has traditional seating with two aisles from back to front. There are 608 seats. Two double doors allow entrance from the back. The auditorium floor is concrete and there is no carpeting. There are no windows in the auditorium, so it can be completely darkened during the daylight hours. At either side of the stage apron, down stage of the proscenium opening, is a stairway to the stage level.

In the original plan for the auditorium, a balcony

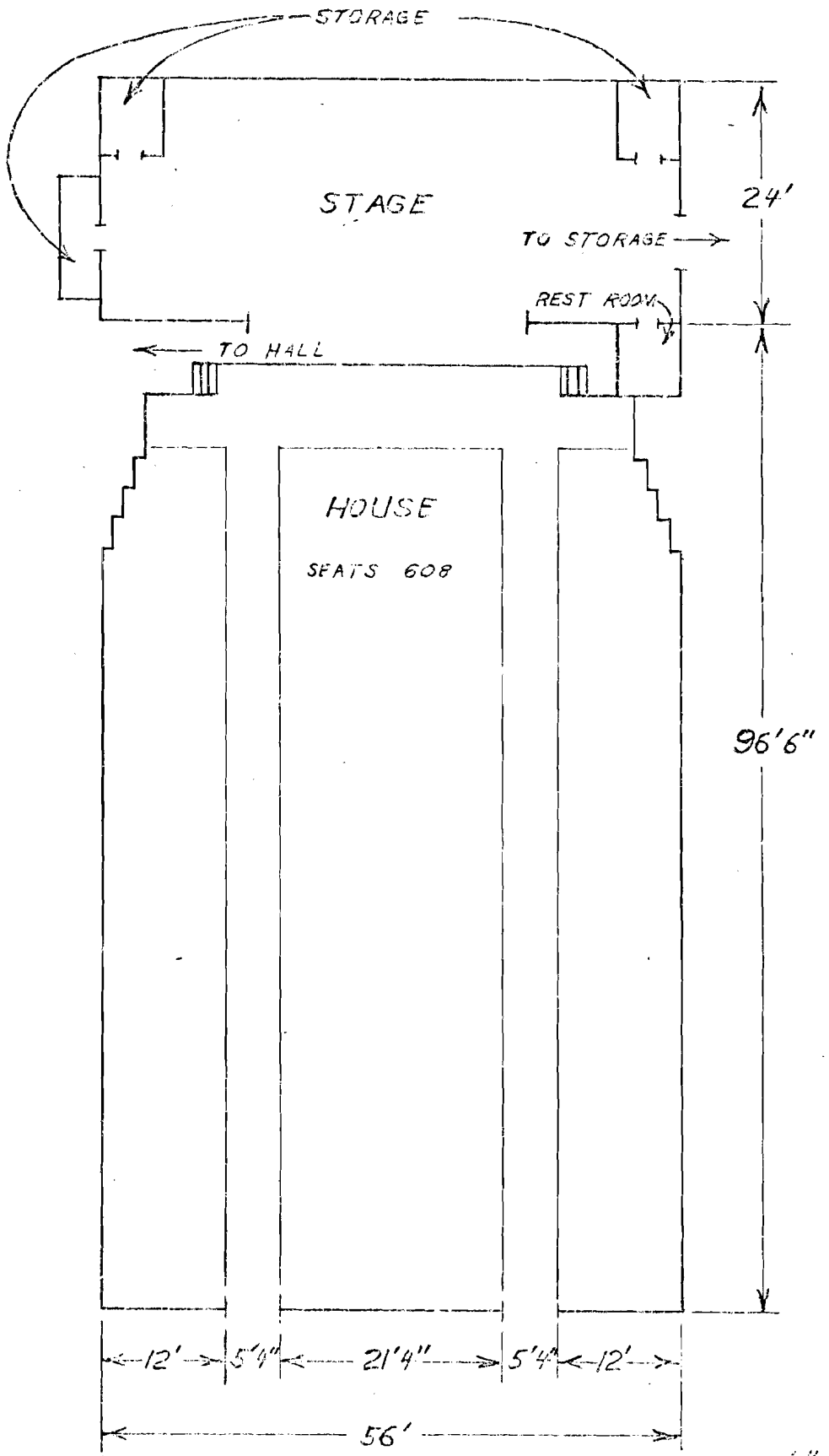

FIGURE 22

AUDITORIUM HOUSE, TONGANOXIE, KANSAS

was provided. It was located above the lobby area. The balcony was 56 feet wide and 35 feet deep. There were no permanent seats installed, and the plan was to set up removable seats when the balcony section was needed. Since the construction of the auditorium, the balcony area has been converted into a band and music room, and is no longer functional as a theatre balcony.

The lobby at the rear of the auditorium is adjoined by hallways to the rest of the school building. There are 1,020 square feet of lobby space with two 6 foot double doors leading to the outdoors. There is neither ticket booth, nor coat check. A detailed drawing of the lobby area may be seen in Figure 24 on page 85.

STAGE AREA

The stage at Tonganoxie High School is of the proscenium type. The proscenium opening is 27 feet wide and 12 feet 3 inches high. The distance from the apron to the first row of seats is 7 feet 10 inches. The apron width is 4 feet 4 inches. The stage has a shallow loft of 18 feet. There are no fly lines. All curtain and light pipes are permanently hung. Wing space stage left and stage right are identical. There are 234 square feet of space on each side. The floor covering is varnished hard oak. The stage floor is not trapped and there is no orchestra pit. There is no loading door from the stage level to the outside. One restroom is provided on the stage left side of the proscenium and is entered from the

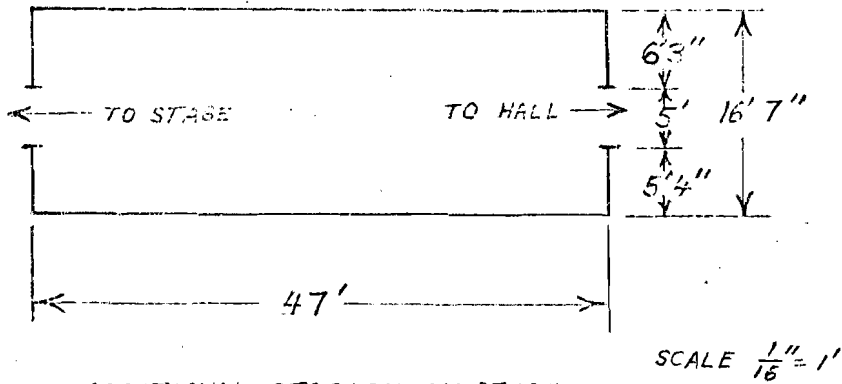

ADDITIONAL STORAGE ON STAGE
AND IN DRAMA CLASSROOM

THIS STORAGE SPACE SHARED
WITH ATHLETIC DEPT.

FIGURE 23
STORAGE, TONGANOXIE, KANSAS

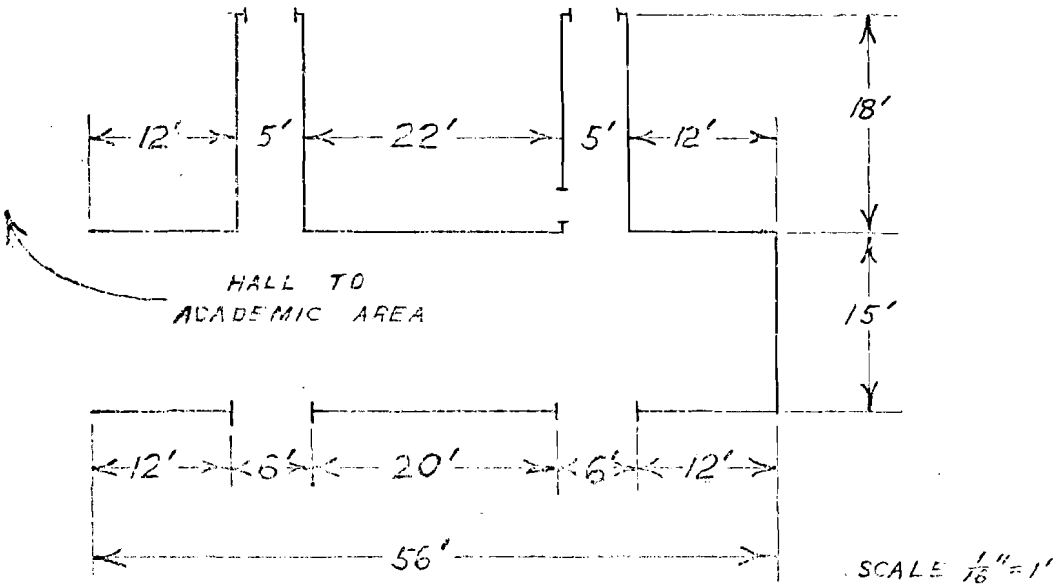

FIGURE 24
LOBBY, TONGANOXIE, KANSAS

stage level. A floor plan of the stage area can be seen in Figure 22, page 83.

CURTAINS AND SCENERY

The stage is equipped with curtains to be used as backing during a performance. There is an act curtain of cotton material and it is lined. Its color is deep red with black specks. There is one matched teaser. There is a loose hanging, tan cotton cyclorama that surrounds the acting area, and there are three teasers of the same material provided for top masking. There is a gray colored, stretched sky cyclorama that measures 26 feet by 13 feet. There are no painted backdrops and there is no scrim.

CONSTRUCTION AREA AND EQUIPMENT

Most of the construction for play production is done on stage. There is no stage construction shop provided. The theatre does not have construction tools. The tools needed for scenery construction are borrowed from the school woodshop, and any special construction requiring power tools is done in the school shop. The school shop offers the space and equipment needed for scenery construction, but its location to the stage is not convenient. There is no loading door from stage to the outside which makes the moving of materials and constructed pieces in and out most difficult.

STORAGE AREA

Three closet-like rooms are located on stage that double as storage rooms and dressing rooms. They are not equipped to serve as dressing rooms, but since no other dressing rooms were provided, they are often used for that purpose. Two of the rooms are identical. One is located stage left, the other stage right. Their dimensions are 6 feet by 9 feet, with an 8 foot ceiling. The ceilings of these rooms provide platforms for storage from the height of the rooms to the ceiling above the stage. The dimensions of the third room are 12 feet by 4 feet, with an 8 foot ceiling, and this room is excellent for the storage of costumes.

A 5 foot door in the stage left wall leads into a large storage room that the theatre shares with the athletic department for storage of athletic equipment. The storage room dimensions are 47 feet by 16 feet 7 inches. The ceiling height is 8 feet. A detailed drawing of the storage area may be seen in Figure 23, page 85. In addition to the storage space described, some make-up and a few small hand props are stored in a classroom closet.

DRESSING ROOMS

No dressing rooms are provided. Dressing and make-up are done in the storage rooms described above or in a classroom. Water is not available in the storage area.

LIGHTING

Tonganoxie High School stage is equipped with a Ward Leonard Vitrohm rheostat three unit dimmer set. The trio of dimmers is hung on the stage right proscenium wall. The capacity of each dimmer is 1,354 watts, making a total dimming capacity of 4,062 watts. There are ten plugs on the first light pipe, none of which are on a dimming circuit. The dimming circuits control the beam position lighting. There are six ellipsoidal reflector spotlights used to light the downstage area, two units to each dimming circuit. Other lighting equipment includes four 6 inch fresnels, two 4 inch fresnels, and 43 feet of three circuit striplighting. The striplights are divided into two banks of lights, one 25 feet long, the other 18 feet long, and all have red, white, and blue rondels. There are four 10 inch floodlights.

The stage is equipped with three electrical outlet pockets. One is located on the stage left proscenium wall. The others are floor pockets, one stage left, the other stage right. In addition to these electrical pockets there are four, two conductor household type electrical outlets located around the walls of the stage. There are no electrical outlets in the pit area. Some electrical drop-cord is available for short runs on stage.

SOUND

There is no sound booth. The sound is operated from a cabinet constructed against the stage right wall. The cabinet houses a 160 watt, DuKane amplifier. There is a four-speed turntable provided, but no tape deck. There are two house speakers, one hung on the wall on either side of the proscenium opening. A microphone pick-up jack is located in the stage right and stage left floor. One microphone is provided, a DuKane dynamic cardioid model 7A160.

COMMUNICATIONS

The stage equipment does not include a running crew communication system.

Chapter 12

SUMMARY AND CONCLUSIONS

The following two pages provide a table which summarizes the equipment and space provided for theatrical productions in each of the ten Class AAA high schools studied.

AUDITORIUM HOUSE

All of the facilities included in the study were constructed since 1900, the earliest being completed in 1931, and the latest in 1969. Three of the ten structures are auditorium-gymnasium combinations.

The lobby space in many of the theatre structures is far from adequate. There is a lack of conveniently located rest room facilities. A ticket booth is provided in only six of the ten structures studied, and only one of the ten schools provides a coat check. Additional consideration should be given to the comfort and convenience of the audience members by providing adequate lobby facilities.

STAGE AREA

Each of the ten theatres is designed with a proscenium stage. The stage size in each theatre structure

| SPACE AND EQUIPMENT SUMMARY | Atchison | | Buhler | | Decatur Comm. Oberlin | | Gardner | | Lyons | | Neodesha | | Ottawa | | Parsons | | St. Joseph's Hays | | Tonganoxie | | |
|-----------------------------|----------|-----|--------|-----|-----------------------|-----|---------|-----|-------|-----|----------|-----|--------|-----|---------|-----|-------------------|-----|------------|-----|-------|
| | No | Yes | No | Yes | No | Yes | No | Yes | No | Yes | No | Yes | No | Yes | No | Yes | No | Yes | No | Yes | |
| Scrim | No | | No | | No | | No | | No | | No | | No | | No | | No | | No | | |
| Construction Area Adequate | Yes | | No | | No | | No | | No | | No | | No | | No | | No | | Yes | | No |
| Const. Eq. Adequate | No | | No | | No | | No | | No | | No | | No | | No | | No | | No | | No |
| Storage Area Adequate | Yes | | No | | No | | No | | No | | No | | No | | No | | No | | Yes | | No |
| Dressing Rooms | Yes | | No | | No | | No | | No | | No | | No | | No | | No | | Yes | | No |
| Provided | Yes | | No | | No | | No | | No | | No | | No | | No | | No | | No | | No |
| DR Adequate | No | | -- | | -- | | -- | | -- | | -- | | -- | | -- | | -- | | -- | | -- |
| Water Avail. | Yes | | -- | | -- | | -- | | -- | | -- | | -- | | -- | | -- | | -- | | -- |
| Showers | No | | -- | | -- | | -- | | -- | | -- | | -- | | -- | | -- | | -- | | -- |
| Proper Light | No | | -- | | -- | | -- | | -- | | -- | | -- | | -- | | -- | | -- | | -- |
| Conven. Loc. | No | | -- | | -- | | -- | | -- | | -- | | -- | | -- | | -- | | -- | | -- |
| Lighting | Yes | | No | | No | | No | | No | | No | | No | | No | | No | | No | | No |
| Eq. Adeq. | Yes | | No | | No | | No | | No | | No | | No | | No | | No | | No | | No |
| Dimming | 30,000 | | 12,000 | | 18,000 | | None | | None | | 47,200 | | None | | 15,000 | | 16,000 | | 33,600 | | 4,062 |
| Capacity | Beam | | | | | | | | | | | | | | | | | | | | |
| Pos. Lgt. | Yes | | P.A.R. | | Yes | | None | | None | | Yes | | None | | None | | P.A.R. | | None | | Yes |
| First | 7 | | None | | None | | 10 | | 10 | | 10 | | 6 | | None | | None | | None | | 5 |
| Pipe Cir. | 90 | | 36 | | 50 | | 40 | | 40 | | 140 | | 60 | | 120 | | 48 | | 84 | | 42 |
| Border Lgt. | 16 | | 5 | | None | | 10 | | 10 | | 8 | | None | | None | | 4 | | 7 | | 6 |
| Total Ft. | 6 | | 4 | | None | | None | | None | | 9 | | None | | None | | None | | 1 | | 6 |
| No. of Floodlights | None | | 1 | | None | | 2 | | 2 | | 4 | | None | | None | | None | | None | | 4 |

| SPACE AND EQUIPMENT SUMMARY | Atchison | | Buhler | | Decatur Comm. | | Gardner | | Lyons | | Neodesha | | Ottawa | | Parsons | | St. Joseph's | | Tonganoxie | |
|-----------------------------|----------|------|--------|--------|---------------|------|---------|------|-------|------|----------|------|--------|------|---------|------|--------------|------|------------|------|
| | | | | | | | | | | | | | | | | | | | | |
| No. of Followspots | 2 | 1 | None | 1 | None | 2 | None | 2 | None | None | None | 2 | None | None | None | None | None | None | None | None |
| No. Elect. Floor Pkt. | 7 | 2 | 4 | 2 | 8 | 3 | None | 3 | None | None | 3 | None | None | None | None | None | None | None | None | 3 |
| No. Outlets in Pit | 12 | -- | -- | -- | 12 | 10 | -- | 7 | -- | -- | 7 | -- | -- | 7 | -- | -- | -- | -- | -- | -- |
| Sound System Adequate | Yes | No | No | No | No | No | No | No | No | No | No | No | No | No | No | No | No | No | No | No |
| Sound Booth | Yes | No | No | No | Yes | No | No | No | No | No | No | No | No | No | No | No | No | No | No | No |
| Amplifier Capacity | 180 w | None | 180 w | None | 120 w | None | 200 w | None | 200 w | None | 200 w | None | 200 w | None | 200 w | None | 200 w | None | 160 w | None |
| Tape Deck | 1 | None | None | None | None | None | None | None | None | None | None | None | None | None | None | None | None | None | None | None |
| Turn Table | 1 | None | 1 | None | None | 1 | None | None | 1 | None | None | None | None | None | None | None | None | None | None | 1 |
| No. House Speakers | 2 | 2 | 2 | 7-P.A. | 4 | 4 | 4 | 4 | 4 | 4 | 4 | 4 | 4 | 4 | 4 | 4 | 4 | 4 | 4 | 2 |
| Mic. Pkups. on Stg. | 5 | 1 | 1 | 1 | 3 | 2 | 2 | 2 | 2 | 2 | 2 | 2 | 2 | 2 | 2 | 2 | 2 | 2 | 2 | 2 |
| Adequate Micro. | Yes | No | No | No | Yes | No | No | No | Yes | Yes | Yes | No | No | No | No | No | No | No | No | No |
| Communications System | Yes | No | No | Yes | Yes | No | No | Yes | Yes | Yes | Yes | No | No | Yes | Yes | No | No | No | No | No |

is adequate to produce a play, but in some instances the stage size would seriously limit script selection. Wing area is adequate in only three of the ten facilities.

Consideration should also be given to the necessity of fly gallery area. In only three of the theatres studied is the stage loft functional for flying scenery pieces.

An orchestra pit is provided in four of the ten facilities studied, but in only one instance is the pit adequate for musical production.

The floor covering material on all but two of the stage floors is hard wood, and a polished finish is maintained on nine of the ten floors. Consideration should be given to providing soft wood stage floor material with a dark, light-absorbing finish.

CURTAINS AND SCENERY

All ten of the high school stages studied are equipped with act curtains. All act curtains are rigged to travel open and closed, and in two of the ten theatres the act curtain will also fly.

Five of the ten theatres provide pleated cyclorama curtains for side and rear masking. The remaining five are equipped with legs and traveling drops in wing and drop arrangements. Four of the ten theatres are provided with sky cycloramas. In two cases the sky cycloramas are stretched. The other two are roll-up cycloramas. A scrim is provided in only one of the theatres studied. The curtains are

adequate to achieve masking in each of the ten schools studied.

CONSTRUCTION AREA AND EQUIPMENT

A lack of adequate construction area and equipment is evident in every school studied. In seven of the ten schools, no provisions are made for the necessity of scene construction. Construction area is provided in only three institutions, and in only one case does the construction area approach adequacy. There is a severe lack of construction tools and equipment. None of the schools visited are equipped with the construction tools necessary to accomplish efficient scenery construction. Consideration must be given to the provision of properly equipped scene shops to accomplish scenery construction.

STORAGE AREA

Storage area is found to be completely inadequate in seven of the ten schools studied. In some instances no storage area whatever is provided and all scenery pieces and supplies are stored on the stage floor. In other facilities where large storage rooms are provided, no provision is made for storage of equipment and supplies within the space. In many instances shelf space is at a premium. No provision is made for the storage of dry pigment paint, stage hardware, or lighting equipment. Adequate storage space is a necessary consideration in

theatre planning, and in every school studied improvement is needed in storage facility.

DRESSING ROOMS

A dressing room that is attractive, restful, and convenient is important to the preparation of an actor. Yet in seven of the ten schools studied, a dressing room is not provided. In only one of the facilities can the dressing rooms be considered adequate and convenient for the actors. The actors are supplied with water and toilet facilities in all of the dressing rooms studied, but only one facility is equipped with adequate electrical outlets, mirrors, and lighting for convenient make-up application. None of the dressing rooms are equipped with showers. A definite need exists for improvement of dressing room facilities in 90 percent of the schools studied.

LIGHTING

The lighting systems may be considered adequate in only two of the ten schools studied. In two of the ten theatres, no dimmer system is provided. Eight of the theatres are equipped with dimming devices, but in most instances the dimming capacity is far from adequate. House light circuits and many stage circuits are switched, and are not controlled by the dimming device.

No beam position lighting is provided in four of the ten schools studied. Three of the theatres provide

ellipsoidal reflector spotlights in the beam position. P.A.R. units are provided in two theatres, and one is equipped with 6 inch plano-convex units. In only three of the theatres studied is the beam position lighting adequate.

Five of the ten theatres provide first pipe light circuits. In some instances the first pipe circuits are switched other than being wired to dimming circuits. The number of first pipe circuits available range from five in one theatre to ten in two of the theatres studied. In some instances the light units are wired direct and cannot be unplugged and removed from the pipe. In all theatres studied, three or four circuit striplights are provided. In some instances they are wired to dimming circuits, where as in other theatres they are on switched circuits.

Provisions should be made to provide additional dimming circuits and additional lighting equipment in every facility studied. A severe shortage of lighting equipment is evident in each of the schools visited. There is a shortage of an adequate number of fresnels, ellipsoidal reflector spotlights, and floodlights.

SOUND

A severe lack of sufficient sound equipment is evident in each school studied. In only one of the ten schools could the sound system be termed adequate. Amplifiers are provided in six of the ten schools, but

in most cases the amplifiers are supplied for use as public address systems only. Turntables and tape decks are not provided in most instances. Adequate microphones are not available. A sound booth is provided in only two of the facilities studied, and in one instance the booth is in an area away from the auditorium where visual contact with the performance is impossible.

Consideration must be given to providing sound systems that would enable electronic production of sound effects and vocal amplification from the stage.

COMMUNICATIONS

Four of the facilities studied provide a system which enables communication to take place among members of the running crew during a production. In one case the communication system is portable. The system proves to be extremely versatile because the communication locations are optional. In six of the ten schools studied, no communication system is provided. To assist the stage manager in production control and to assure coordination of technical efforts, consideration should be given to the provision of a communication system.

CONCLUSION

The conclusion drawn from this study is that clear inadequacies exist in the theatre facilities of the ten Kansas high schools studied. The theatre facilities in use

by the ten Class AAA High schools studied do not provide the necessary space, arrangement, and equipment to enable the best quality of instruction and achievement in the techniques of play production.

BIBLIOGRAPHY

BOOKS

- Bell, Stanley, Norman Marshall, and Richard Southern. Essentials of Stage Planning. London: Frederick Muller Ltd., 1949.
- Braden, Waldo W. Speech Methods and Resources. New York: Harper-Row, 1961.
- Bywater, Ingram (trans.). Aristotle: Poetics. New York: The Modern Library, 1954.
- Gillette, Arnold S. Planning and Equipping the Educational Theatre. Cincinnati: The National Thespian Society, College Hill Station, 1945.
- Jones, Robert Edmond. The Dramatic Imagination. New York: Theatre Arts Books, 1941.
- Ogilvie, Mardel. Teaching Speech in the High School. New York: Appleton-Century-Crofts, Inc., 1961.
- Smith, Milton M. The Equipment of the School Theatre. New York: Appleton-Century-Crofts, Inc., 1930.
- Whiting, Frank M. An Introduction to the Theatre. New York: Harper and Brothers, 1954.

PERIODICALS

- Bel, Geddes, Norman, Edward C. Cole, Arch Lauterer, Serge Chermayeff, and Stanley McCandless. "Theatre Planning: A Symposium," Educational Theatre Journal, March, 1950.
- Bowman, Ned A. "The Ideal Theatre: Emerging Tendencies in its Architecture," Educational Theatre Journal, October, 1964.
- Cole, Wendell. "Some Contemporary Trends in Theatre Architecture," Educational Theatre Journal, March, 1955.
- Davison, Robert L. "Procedure in Designing a Theatre," Architectural Record, May, 1930.

- Dewey, Walter S. "More Flexibility from the Front,"
Educational Theatre Journal, January, 1959.
- Evans, Don. "Educational Theater in the High School,"
English Journal, March, 1968.
- Fuchs, Theodore. "Planning A School Theatre," Theatre Arts Monthly, October, 1938.
- Holzman, Malcolm. "The Play's the Thing in Educational Theater Design," American School and University, December, 1968.
- Miller, James H. "Initial Factors in Theatre Planning,"
Educational Theatre Journal, May, 1956.
- Robinson, Horace W. "An Approach to Theatre Planning,"
Educational Theatre Journal, December, 1949.
- Robinson, Marion Parsons. "Don'ts for Theatre Builders,"
Educational Theatre Journal, October, 1951.
- Simonson, Lee. "Basic Theatre Planning," Architectural Forum,
September, 1932.
- Sliker, Harold G. "Theatre Arts in the Secondary School,"
The Speech Teacher, January, 1955.
- Thorpe, Clarence D. "The Educational Function of High School Dramatics," The Quarterly Journal of Speech Education,
February, 1924.

DISSERTATION ABSTRACTS

- Robinson, Marion W. "College Theatres of Tomorrow," Doctoral
Dissertation, University of Wisconsin, 1945.

UNPUBLISHED REPORTS

- North Central Association Evaluation Report, Buhler High
School, February 25, 26, 27, 1970.

APPENDIX

THEATRE FACILITIES QUESTIONNAIRE

Name of school _____ Location _____

Net enrollment _____ Name of interviewer _____

AUDITORIUM HOUSE:

Seating capacity _____

Type of seating _____
(traditional, continental, removable, other)

Plan of auditorium house:

Lobby space _____ sq. ft.

Coat check _____ (yes-no)

TYPE OF STAGE:

Proscenium type _____ (yes-no) Other _____

Distance from front row to apron _____ ft.

Width of proscenium _____ ft. Height of proscenium _____ ft.

Height of loft _____ ft. (If no loft, write no)

Wing space:

Left _____ sq. ft.

Right _____ sq. ft.

Floor covering material _____

Stage floor trapped _____ (yes-no) Orchestra pit _____ (yes-no)

Number of fly lines _____ (If none, write no)

Number of dead lines _____

Number of counterweighted lines _____

Plan of stage area:

CURTAINS AND SCENERY:Act curtain _____ Type of material _____
(yes-no)Cyclorama _____ Type _____
(yes-no)Legs and drops _____ Description _____
(yes-no)Number of painted backdrops _____
Number that are professionally painted _____.
Number that are painted by amateurs _____.Scrim _____ Description _____
(yes-no)CONSTRUCTION AREA AND EQUIPMENT:

Construction space _____ sq. ft.

Construction area accessible to stage _____
(yes-no)Construction area accessible to loading door _____
(yes-no)Construction equipment:
List hand tools

List power tools

Plan of construction area:

Height of ceiling _____ ft.

STORAGE SPACE:

Scenery_____ cub. ft.
Property_____ cub. ft.
Paint_____ cub. ft.
Hardware_____ cub. ft.
Costumes_____ cub. ft.
Make-up_____ cub. ft.
Lighting equipment_____ cub. ft.
Sound equipment_____ cub. ft.

Plan of storage areas:

DRESSING ROOMS:

Men
 Size _____ sq. ft.
 Hot and cold water _____ (yes-no)
 Number of lavatory spaces _____
 Number of electrical outlets _____
 Number of dressing tables _____
 Type of make-up lighting _____
 Showers _____ (yes-no)

Women
 Size _____ sq. ft.
 Hot and cold water _____ (yes-no)
 Number of lavatory spaces _____
 Number of electrical outlets _____
 Number of dressing tables _____
 Type of make-up lighting _____
 Showers _____ (yes-no)

Plan of dressing rooms:

LIGHTING:

Number of fresnels _____ Size _____ inch Brand _____
 Number of ellipsoidal reflectors _____ Size _____ in. Brand _____
 Number of feet of strips _____ Number of units per strip _____
 Brand _____
 Number of floods _____ Size _____ inch Brand _____
 Number of followspots _____ Size _____ inch Brand _____
 Other _____

Number of feet of electrical cable _____
 Number of plugs on first pipe _____
 Number of electrical floor pockets _____
 Number of electrical outlets in orchestra pit _____
 Number of other electrical plugs _____ Location _____
 Beam position lighting _____ Type _____
 (yes-no)

DIMMERS:

Type _____
 Brand _____
 Number of dimmers _____
 Location _____
 Capacity _____ thousand watts per dimmer
 Total capacity _____ thousand watts

SOUND:

Location of sound booth _____

Amplifier capacity _____ watts

Number of circuits _____

Turntable:

Number of turntables _____
 Brand _____
 Speeds _____

Tape deck:

Number of tape decks _____
 Brand _____
 Speeds _____
 Tracks _____

Number of house speakers _____

Number of speaker outputs located on stage _____
 Location _____

Number of microphone pick-ups located on stage _____
 Location _____

Number and type of microphones used _____

COMMUNICATIONS: (place an "X" in the space provided to indicate communication connections)

_____ Light board
_____ Sound booth
_____ Beam position
_____ Stage manager area
_____ Stage right
_____ Stage left
_____ Dressing rooms
_____ Followspot positions

COMMENTS: